

**ELECTROPHYSIOLOGICAL EFFECTS OF SOME ANALGESIC
POLYPHENOLS ON DORSAL ROOT GANGLIA NEURONS**

Ahmed Abduljalil Radman HASAN

MASTER THESIS

Supervisor: Prof. Dr. Yusuf OZTURK

Eskisehir

Anadolu University

Graduate School of Health Sciences

June 2021

JÜRİ VE ENSTİTÜ ONAYI

ÖZET

ANALJEZİK ETKİLİ BAZI POLİFENOLLERİN DORSAL KÖK GANGLİYON NÖRONLARI ÜZERİNDEKİ ELEKTROFİZYOLOJİK ETKİLERİ

Ahmed Abduljalil Radman HASAN

Farmakoloji Anabilim Dalı

Anadolu Üniversitesi, Sağlık Bilimleri Enstitüsü, Haziran 2021

Danışman: Prof. Dr. Yusuf ÖZTÜRK

Ağrı, hastaların üretkenliğini sınırlayan ve yaşam kalitesini düşüren sağlık sorunlarından biridir. Birçok analjezik ajan varlığına rağmen, bunların güvenlikleri ve yan etkileri konusunda büyük bir endişe vardır. Kersetin ve diğer bazı polifenoller, antienflamatuar, analjezik ve antioksidan ajanlar olarak önem taşımaktadır. Bu çalışma, üç test maddesinin (rozmarinik asit, kersetin ve gallik asit) hücre uyarılabilirliği ile ilgili parametreler açısından etkisini araştırmak için primer dorsal kök ganglion hücreleri üzerinde gerçekleştirilmiştir. Patch clamp tekniğinin tüm hücre konfigürasyonu, toplam dışa doğru akımları ve aksiyon potansiyeli parametrelerini değerlendirmek için kullanılmıştır. Kontrol grupları, aynı hayvandan alınan aynı test hücre gruplarıdır. Dorsal kök ganglion hücrelerinden alınan elektrofizyolojik kayıtlar, rozmarinik asit, kersetin ve gallik asidin, test edilen membran potansiyeli aralığında maksimum K^+ iletkenliğini önemli ölçüde azalttığını ve tepe akımı ve iletkenliği daha pozitif membran potansiyellerine kaydırıldığını göstermiştir. Buna ek olarak, kimyasalların uygulanmasından sonra, K^+ akımları için sonuç olarak gözlemlenen etkiye benzer şekilde, aksiyon potansiyeli parametreleri belirgin bir inhibisyon yönünde değişmiştir. Elde edilen sonuçlar, maddelerin K^+ akımları üzerindeki indüklediği inhibisyonun konsantrasyona bağlı olmadığını göstermektedir. Sonuç olarak, bu çalışmada kullanılan fitokimyasalların ağrıyı hafifletme potansiyeline sahip olduğunu açıkça ortaya konmuştur ve bu çalışmaya dayalı daha ileri araştırmalar etkili bir yaklaşım sağlayacaktır.

Anahtar Sözcükler: Kersetin, Gallik asit, Rozmarinik asit, Patch clamp, Ağrı.

ABSTRACT

ELECTROPHYSIOLOGICAL EFFECTS OF SOME ANALGESIC POLYPHENOLS ON DORSAL ROOT GANGLIA NEURONS

Ahmed Abduljalil Radman HASAN

Department of Pharmacology

Anadolu University, Graduate School of Health Sciences, June 2021

Supervisor: Prof. Dr. Yusuf OZTURK

Pain is one of the conditions that limit the productivity and decrease the quality of life of affected patients. Despite the presence of plenty of effective analgesic, there is a great concern regarding their safety and adverse effects. Quercetin and some other polyphenols play an important role as anti-inflammatory, analgesic, and antioxidant agents. This study was performed on acutely dissociated dorsal root ganglion cells to investigate the effect of three agents (rosmarinic acid, quercetin, and gallic acid) in terms of parameters about cell excitability. The whole cell configuration of the patch clamp technique has been used to evaluate total outward currents and action potential parameters. Control groups were the same test cell groups taken from the same animal. Electrophysiological recordings from dorsal root ganglion cells showed that rosmarinic acid, quercetin, and gallic acid significantly reduce maximal K^+ conductance over the membrane potential range tested and shift the peak current and conductance towards more positive membrane potentials. Action potential parameters have been changed after the administration of the chemicals in favor of an inhibition, like the effect observed consequently for K^+ currents. Results obtained indicates that the inhibition on K^+ currents the substances induce is not concentration dependent. In conclusion, this study clearly presented that the phytochemicals used have the potential to be promising drugs to relieve pain and further research based on this study will provide an efficient approach.

Keywords: Quercetin, Gallic acid, Rosmarinic acid, Patch clamp, Pain.

ACKNOWLEDGEMENTS

June 2021

First of all, I would deeply like to thank my supervisor Prof. Dr. Yusuf ÖZTÜRK for giving me a chance to do my master thesis under his supervision. I am grateful for his guidance throughout this work. It was a pleasure to work in his well-equipped laboratory.

I thank Dr. Feyza ALYU for initiating this interesting project and his support during my study, for her patience, respect, teachings, and confidence in my work. Her support for new ideas, discussions, and never-ending optimism helped me achieve the goal of my project.

I would like to thank to Prof. Dr. yusuf ÖZTÜRK and Dr. feyza alyu also for providing me the honor of performing the first thesis work with the patch clamp technique in faculty of pharmacy in Turkey.

I am grateful to Prof. Dr. Alexander ZHOLOS, who has spared so many hours for our team whenever necessary during our work and provided invaluable scientific progress, just like Prof. Dr. Ramazan BAL who has given our team a great support, and also Prof. Dr Nilgün ÖZTÜRK for supplying the test chemicals. I also would like to thank to Dr. Jan DOZLER for his support, clarifications, and teachings.

I would like to thank Dr. Yusuf OLGAR for his guidance and teachings when we had come across to the problems experimentally and helping with data analysis. His useful advice helped me during my studies and made the work more focused and therefore easier. My deepest thanks to colleagues and friends in the laboratory, Raouf and Ilham, for the joyful and difficult time we spend together. I would like to especially thank my friends Sam DAWBA, Wail MURSHID, Elias ALSAMAI and Haitham ALSHARI for being always ready to help me substantially in carrying out the work.

Finally, I would like to thank all my family for their unlimited support, especially my beloved mother for standing beside me and supporting me with everything I need, her prayer used to reach me in every difficult stage I went through.

STATEMENT OF COMPLIANCE WITH ETHICAL PRINCIPLES AND RULES

I hereby declare that this thesis is my own original work prepared by me; I have worked in compliance with scientific ethical rules principles during all stages and processes including preparation, data collection, analysis, report presentation and presentation of the results; I have cited all the sources of the data and information obtained from this study, and these sources have been included in the reference section; And this study has been examined for plagiarism with "scientific plagiarism detection program" used by Anadolu University, and no plagiarism was identified. I declare that I consent all moral and legal consequences that will arise in the event of a problem contrary to this statement I have made regarding my work.

TABLE OF CONTENTS

	<u>Page</u>
JÜRİ VE ENSTİTÜ ONAYI.....	ii
ÖZET	iii
ABSTRACT.....	iv
ACKNOWLEDGEMENTS	v
STATEMENT OF COMPLIANCE WITH ETHICAL PRINCIPLES AND RULES	vi
TABLE OF CONTENTS	vii
LIST OF FIGURES	x
LIST OF TABLES	xi
LIST OF SYMBOLS AND ABBREVIATIONS	xii
1. INTRODUCTION	1
1.1. Background.....	1
1.2. Objective	1
2. LITERATURE REVIEW	2
2.1. Polyphenols	2
2.1.1. Rosmarinic acid.....	2
2.1.2. Gallic acid	5
2.1.3. Quercetin.....	7
2.2. Pain.....	8
2.2.1. Classification of pain.....	8
2.2.1.1. <i>According to the duration</i>	8
2.2.1.2. <i>According to the mechanism</i>	9
2.2.2. Neuroanatomy and physiology of pain perception	12
2.2.3. Modulation of pain sensitivity.....	15
2.3. DRG	17

	<u>Page</u>
2.3.1. Anatomy of DRG neurons and clinical significance	17
2.3.2. Ion channels in DRG.....	18
2.3.2.1. <i>Sodium channels</i>	18
2.3.2.2. <i>Potassium channels</i>	18
2.3.2.3. <i>Calcium channels</i>	18
2.3.2.4. <i>TRP channels</i>	19
2.4. Electrophysiology	19
2.4.1. The resting potential	19
2.4.2. The AP.....	20
2.4.3. The conduction of excitation	20
3. MATERIALS AND METHOD	22
3.1. Materials	22
3.2. The Patch-Clamp Technique	22
3.3. Animals	24
3.4. DRG dissection	24
3.5. Electrophysiology	25
3.5.1. Voltage-clamp recordings.....	25
3.5.2. Current-clamp recordings.....	26
3.6. Solutions.....	27
3.7. Statistical Analysis	27
4. RESULTS	28
4.1. Effect of GA on K ⁺ peak current	28
4.1.1. GA 01 μM.....	28
4.1.2. GA 10 μM.....	29
4.1.3. GA 100 μM.....	30
4.2. Effect of Quercetin on K ⁺ peak current	31
4.2.1. Quercetin 1 μM	31

	<u>Page</u>
4.2.2. Quercetin 10 μ M	32
4.2.3. Quercetin 100 μ M	33
4.3. Effect of RA on K ⁺ peak current	34
4.3.1. RA 1 μ M.....	34
4.3.2. RA 10 μ M.....	35
4.3.3. RA 100 μ M.....	36
4.4. Concentration dependent effect	37
4.5. Effect of pharmacological agents on the AP parameters	38
4.5.1. GA effect	38
4.5.2. Quercetin effect	40
4.5.3. RA effect.....	42
DISCUSSION.....	44
CONCLUSION	47
REFERENCES.....	48
APPENDICE I	
APPENDICE II	
CURRICULUM VITAE	

LIST OF FIGURES

Page

Figure 2.1. Potential action of polyphenols in different pathologies [4].	2
Figure 2.2. Chemical structure of RA	4
Figure 2.3. Chemical structure of GA	6
Figure 2.4. Chemical structure of quercetin	7
Figure 2.5. Neuroanatomy of nociception and the fibers carrying pain sensation [95].	13
Figure 2.6. Modulation of pain sensitivity and signaling components in nociceptor [154]	16
Figure 2.7. DRG neurons as part of the reflex arc	17
Figure 3.1. Schematic representation of a patch-clamp arrangement in a whole-cell configuration [142]	22
Figure 3.2. Schematic representation of various patch configurations [142]	23
Figure 3.3. Photo of a pipette and DRG cell in whole-cell mode (40x magnification).	24
Figure 4.1. K ⁺ current in DRG neurons and their modulation by GA 1 μM.	28
Figure 4.2. K ⁺ current in DRG neurons and their modulation by GA 10 μM.	29
Figure 4.3. K ⁺ current in DRG neurons and their modulation by GA 100 μM.	30
Figure 4.4. K ⁺ current in DRG neurons and their modulation by quercetin 1 μM.	31
Figure 4.5. K ⁺ current in DRG neurons and their modulation by quercetin 10 μM.	32
Figure 4.6. K ⁺ current in DRG neurons and their modulation by quercetin 100 μM.	33
Figure 4.7. K ⁺ current in DRG neurons and their modulation by RA 1 μM.	34
Figure 4.8. K ⁺ current in DRG neurons and their modulation by RA 10 μM.	35
Figure 4.9. K ⁺ current in DRG neurons and their modulation by RA 100 μM.	36
Figure 4.10. Concentration dependent effect of GA	37
Figure 4.11. Concentration dependent effect of RA	37
Figure 4.12. Concentration dependent effect of quercetin	37
Figure 4.13. GA decrease AP amplitude and increase duration for evoked AP by injection a current	38
Figure 4.14. Quercetin decreases the amplitude, increases the duration of AP	40
Figure 4.15. Changing of AP parameters after adding RA.	42

LIST OF TABLES

	<u>Page</u>
Table 2.1. Symptoms and sensitive signs in neuropathic pain [77].....	10
Table 2.2. Classification of the peripheral nerve fibers.	14
Table 4.1. The table AP parameters before applying the chemicals.....	39
Table 4.2. The table showing the effect of three doses of GA 1, 10 and 100 μ M on AP parameters.	39
Table 4.3. The table showing AP parameters before applying the chemical.	41
Table 4.4. The table showing the effect of three doses of quercetin 1, 10 and 100 μ M on AP parameters.	41
Table 4.5. The table showing AP parameters before applying the chemical.....	43
Table 4.6. The table showing the effect of three doses of RA 1, 10 and 100 μ M on AP parameters.....	43

LIST OF SYMBOLS AND ABBREVIATIONS

6-OHDA	: 6-Hydroxydopamine
AHP	: After-hyperpolarization
AP	: Action Potential
APD 90%	: Action Potential Duration at 90%
ATP	: Adenosine Triphosphate
CAMP	: Cyclic Adenosine Monophosphate
CGRP	: Calcitonin Gene-Related Protein
DMEM	: Dulbecco's Modified Eagle's Medium
DRG	: Dorsal Root Ganglion
EDTA	: Ethylenediaminetetraacetic Acid
EG	: Equilibrium potential of the ion (V)
EGTA	: Ethylene Glycol Tetra acetic Acid
ERK1/2	: Extracellular Signal-Regulated Kinase 1/2
F	: Faraday constant 9.6485 (C .mol ⁻¹)
FBS	: Fetal Bovine Serum
GA	: Gallic Acid
G_K	: Potassium Conductance
HEPES	: Hydroxyethyl-Piperazine ethane-Sulfonic acid
IASP	: The International Association for the Study of Pain
I_K	: Potassium Current
IL	: Interleukin
IPA	: Integrated Patch Amplifier
i.p	: Intraperitoneal
K_v	: Voltage Gated K ⁺ Channels
LPS	: Lipopolysaccharide
MARK4	: Microtubule Affinity Regulating Kinase 4
n	: Number of the cells
Nav	: Voltage-gated Na ⁺ channels
NF- κ B	: Nuclear Factor Kappa B
NGF	: Nerve Growth Factor
p	: Probability Value

PKA	: Protein Kinase A
R	: General gas constant 8.31451 (J.mol ⁻¹ .K ⁻¹)
RA	: Rosmarinic Acid
ROS	: Reactive Oxygen Species
S.E.M	: Standard Error of Mean
STZ	: Streptozotocin
T	: Temperature (K)
TNF- α	: Tumor Necrosis Alpha
TRP	: Transient Receptor Potential
TRPA1	: Transient Receptor Potential Ankyrin 1
TRPV1	: Transient Receptor Potential Vanilloid 1
TTCCs	: T-type Ca ²⁺ Channels
UVA	: Ultra Violet A
V _{1/2}	: Voltage of half activation
z	: Valence of the ion
μ M	: Micromolar

1. INTRODUCTION

1.1. Background

There are many different types of flavonoids which consist of polyphenolic groups, so quercetin, GA and RA considered of the best naturally occurred flavonoids, abundantly found in vegetables, fruits and other herbs [1]. They are bioactive compounds that have been extensively studied because of their extraordinary ability to act as pro-oxidants in high doses or antioxidants in low doses depending on their concentrations [2]. There is a lot of evidence advocating that these polyphenols have pharmacological actions and therapeutic potential for treatment and prevention of different diseases. They have been described as cellular protective agents for their antioxidant activity, as well as their anti-inflammatory and antinociceptive effects. Also they have been proven to affect lipid level [3–5].

1.2. Objective

However, there is not enough knowledge about the electrophysical effects of these polyphenols on the currents in the dorsal root ganglia (DRG) neurons, especially for the parameters studied in this thesis work. This study has been conducted *in vitro* to investigate the electrophysiological effects of the test chemicals on DRG of the rats and exhibiting the effect on potassium (K^+) current and action potential (AP) parameters, so that these phytochemicals may be more in the focus of pain research.

2. LITERATURE REVIEW

2.1. Polyphenols

Polyphenols are a class of the molecules that has been associated with therapeutic action in several pathologies. They are present essentially in fruits, vegetables, cereals, legumes and chocolate. Some fruits like grapes, apples, cherries and red fruits contain up to 200-300 mg of polyphenols per 100 g of fresh weight [4]. We ingest 10 times more of these compounds than Vitamin C [6].

At the end of the last century, there was strong scientific evidence, linking long-term polyphenol intake to a protective effect on diseases (Figure 2.1) such as cancer, cardiovascular, neurodegenerative diseases, asthma, diabetes, inflammatory diseases, osteoporosis and aging [3, 4].

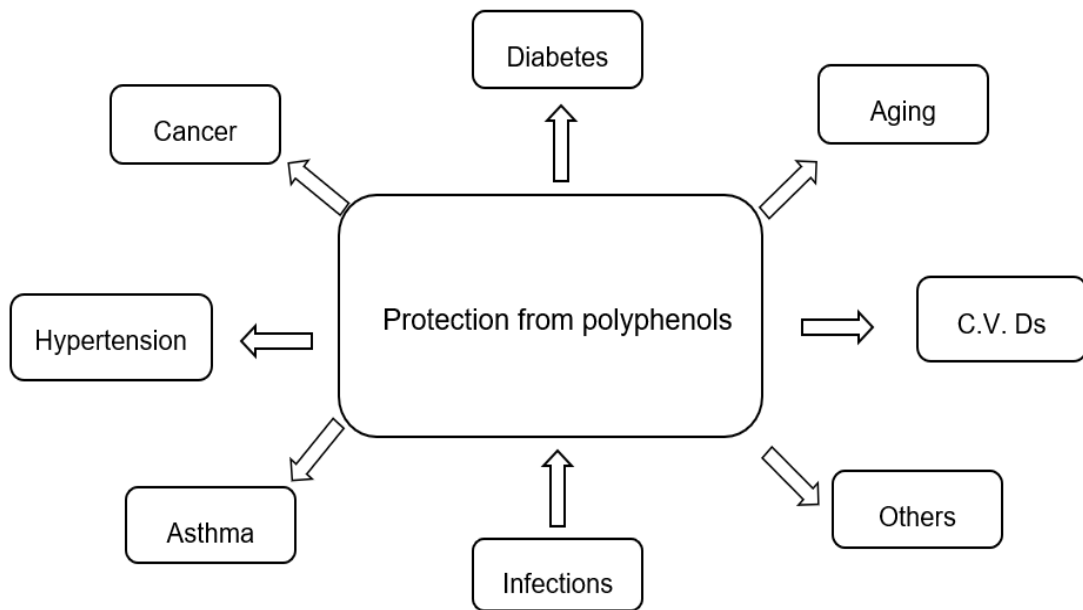

Figure 2.1. Potential action of polyphenols in different pathologies [4].

2.1.1. Rosmarinic acid

Rosmarinic acid (RA), is a phenolic compound derived from caffeic acid and 3,4-dihydroxyphenylacetic acid isolated for the first time in 1958, commonly found in medicinal plants such as rosemary (*Rosmarinus officinalis*), melissa (*Melissa officinalis*), and sage (*Salvia officinalis*). RA has a number of pharmacological activities

observed in several *in vitro* and *in vivo* studies [7], such as antiviral, antibacterial, anti-inflammatory, antitumor and antioxidant [8–11].

An important characteristic of RA is its considerable antioxidant capacity, which is largely responsible for its neuroprotective action, through its the scavenging activity on the reactive oxygen species (ROS) such as peroxy nitrite and hydrogen peroxide [12]. In addition, due to its ability to decrease cell damage induced by ROS, RA also has anti-apoptotic activity, especially by increasing the potential of mitochondrial membrane and inhibiting caspase-3 activity [13].

With the evidence that RA has an important antioxidant effect, interest arises to verify whether it has any neuroprotective effect in models of neurodegenerative diseases related to the production of ROS. In *in vivo* studies, using models of Alzheimer's disease and amyotrophic lateral sclerosis in mice, it was demonstrated that RA significantly reduced the memory deficit associated with neurotoxicity induced by the A β 25-35 protein, delaying the disease onset and prolonging life expectancy in transgenic mice that express the copper zinc superoxide dismutase gene [14, 15]. In other studies it was illustrated that cognitive deficits induced by hypoxia/ischemia was improved and RA promoted the proliferation of oligodendrocytes in the subventricular zone [16]. In addition, it has been shown that RA has an important anticholinesterase action in *in vitro* experiments, and these results are important to explain the effect of improving memory disorders [17]. It has also been demonstrated that RA has a neuroprotective effect in the *in vivo* model of Parkinson's disease induced by 6-hydroxydopamine (6-OHDA) in rats. In that study, the authors demonstrated that RA has an important protective effect on dopaminergic neurons against 6-OHDA-induced neurotoxicity through its antioxidant and anti-apoptotic properties, indicating its potential in the treatment of Parkinson's Disease [18, 19].

RA also has important cardiovascular effects. A study on the effects of RA on the formation of atherosclerotic plaque in mice deficient in apolipoprotein E showed that this substance can reduce the concentrations of total cholesterol, triglycerides, and low-density lipoproteins, decreasing the atherosclerotic plaque in the aortic cavity. Thus, it was concluded that RA can inhibit the progression of atherosclerosis, which is probably related to the actions in the regulation of lipid metabolism and in the inhibition of the inflammatory reaction that occurs during the progression of atherosclerosis [20]. It also

has been shown that RA mitigated cardiomyocytes apoptosis and improving doxorubicin-induced cardiotoxicity [21].

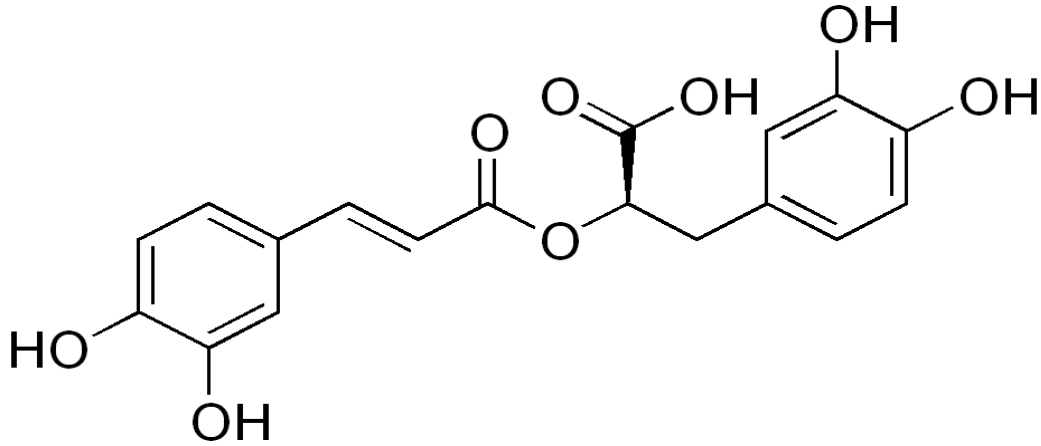

Figure 2.2. Chemical structure of RA

Many studies have shown that RA has a significant anti-inflammatory effect in different animal models. The first anti-inflammatory properties of RA have been demonstrated through its ability to block complement fixation and inhibit lipoxygenases and cyclooxygenases [22]. According to results published in 2021, RA exerts a neuroprotective effect and inhibits lipopolysaccharide (LPS) induces neuroinflammation causing memory impairment and increase cognitive decline [23]. Another study published in 2020 showed that RA inhibits inflammation induced by LPS in peripheral blood mononuclear cells [24]. RA also reduces the concentrations of IL-4 and IL-5 in a model of respiratory allergy and decreases the production of Tumor necrosis factor alpha (TNF- α), IL-6 and IL-1 β in a LPS-induced lung injury model [25, 26].

The normal functioning of the Nuclear Factor Kappa B (NF- κ B) is important for the balance between life and death of the cell. TNF- α is a potent activator of NF- κ B, which in turn is a potent inducer of TNF- α . This positive feedback is the key to chronic inflammatory conditions, such as rheumatoid arthritis. Standard therapy for these conditions includes NF- κ B blockers, such as acetylsalicylic acid and glucocorticoids. However, these drugs have considerable adverse effects that limit their use in humans. RA, being a non-toxic regulator of TNF- α -induced NF κ B activation, appears to be a promising substance in the treatment of diseases involving inflammation, it also has activity in induced-arthritis using Freund's complete adjuvant in Wistar rats [27–29].

The action of RA on cancer has been studied in melanogenesis in B16 melanoma cells, RA was able to induce melanin synthesis by activating protein kinase A (PKA), and thus, acting as a preventive against skin cancer [30]. This substance also had a stimulating action on the expression of tyrosinase *in vitro*, a key enzyme of melanogenesis, and the ability to inhibit skin cancer caused by exposure to UVA radiation, which can be studied as a possible photoprotective agent [31]. Researchers have illustrated that microtubule affinity regulating kinase (MARK4) that control the early steps of cell division is considered a potential target for RA, where it is inhibited by RA [8].

The effect of RA on ion channels, particularly voltage-gated channels, is currently unknown, and there is little known about the effect. It was illustrated that the effect of RA on T-type calcium channels (TTCCs) using the patch-clamp technique in whole-cell configuration, TTCCs play an important role in the neuronal excitability, sensory process, neuroprotection, and sleep, Electrophysiological recordings were conducted on TTCCs (Cav3.2) expressed in HEK-293T cells, the results showed significantly inhibition of Cav3.2 current in a concentration dependent manner and shifted the steady state of inactivation towards more negative value [32].

2.1.2. Gallic acid

Gallic acid (GA) (3, 4, 5-trihydroxybenzoic acid) is a polyphenol produced naturally in plants which is found in herbal foods, beer, red wine, green tea, and pomegranate. Its most important source is tea. It was also obtained from oak trees, chestnuts, and grapes. In a study conducted on rats the results showed that GA has protective activity to lysosomal membrane against isoproterenol that induce cardiotoxic damage and returns lysosomal enzyme activity to near the normal level, this protective effect of GA is due to its anti-oxidant and anti-peroxidation effects [33, 34]. Moreover, it is involved in the prevention of arteriosclerosis [35]. GA has been described as a powerful natural antioxidant scavenging ROS, such as superoxide anion, hydrogen peroxide, hydroxyl radicals [36]. In addition to its antioxidant effects, GA has antifungal, antiviral and antitumor effect and cytotoxic effects on some cancer cells [37]. In a study on diabetes, GA was found to have antihyperglycemic and antilipidemic effects in streptozotocin (STZ)-induced type II diabetic rats [38].

GA has been demonstrated to have neuroprotective activities, a cerebral ischemia model was created, and GA treatment was applied on oxidative stress due to ischemia,

they concluded that it would be useful in reducing neuronal damage caused by cerebral ischemia [39].

Another study of GA to investigate its neuroprotective effect, a chronic stress model was created and behavioral changes caused by stress were evaluated in terms of locomotor activity, anxiety-like behaviors and memory retention, the results obtained revealed that trimethyl GA esters could correct the chronic stress induced behavioral and biochemical changes [40]. Sarkaki and his colleagues tried GA against the effects of traumatic brain damage on behavioral, electrophysiological, and inflammatory disorders. They emphasized that GA improved hippocampal long term potentialization indexes and consequently memory functions, inflammatory parameters are improved, and as a result, it has a neuroprotective effect [41].

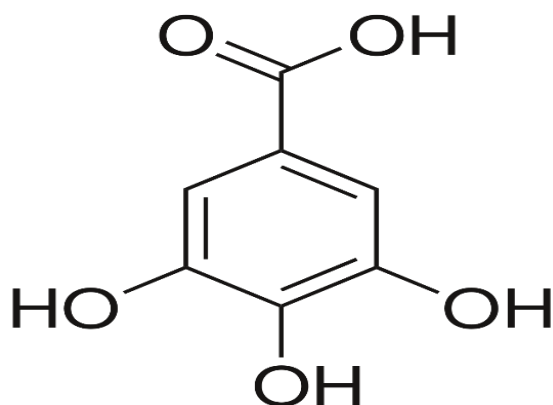

Figure 2.3. Chemical structure of GA

The GA was identified as (Transient Receptor Potential ankyrin1) TRPA1 antagonist and presented antiedematogenic and antinociceptive effects [42]. A recent study using whole cell patch clamp technique investigated the effect of GA on cardiac electrophysiological properties such as its effect on voltage gated sodium channel current and aconitine induced arrhythmia they found that GA inhibited I_{Na} in rat ventricular myocytes and aconitine induced arrhythmia, so it may serve as a potential anti-arrhythmic and cardio-protective agent [43]. GA has been demonstrated to have therapeutic effect on the voltage gated K^+ channels (KV) in the plasma membrane of prostate cancer cells [44].

2.1.3. Quercetin

Quercetin is considered one of the most common type polyphenols (3,3',4',5,7-pentahydroxyflavone) of low molecular weight that exists in human diet mainly in onion, tomato, apple and other red-colored vegetables and fruits [45]. It has been reported to have Antioxidant [46, 47] anti-inflammatory, antiallergic, cardiovascular protective effect [47, 48] anticoagulant, anti-ischemic effects [49] and anticarcinogenic [50]. It has also been reported that quercetin alleviates diabetic neuropathy in mice [51], suppresses the expression of high glucose-induced pro-inflammatory cytokine [52], and causes a decrease in plasma corticosterone levels [46].

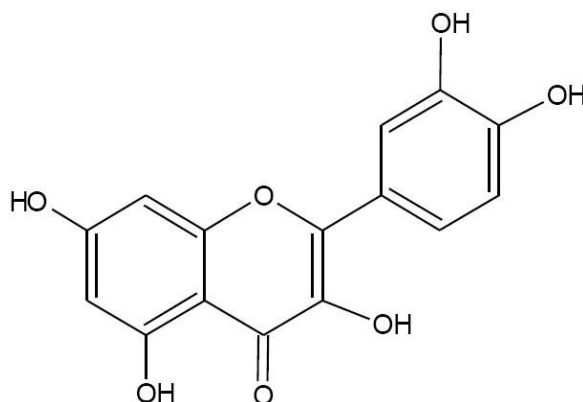

Figure 2.4. Chemical structure of quercetin.

The effects of quercetin on the central nervous system have been examined. Quercetin was shown to have adrenoreceptor-mediated antinociceptive effects [53], anxiolytic and antidepressant effects [54, 55]. Quercetin has been reported to shorten the immobility period in diabetic mice [56]. In addition, it was reported that it has an improving effect on learning and memory [57], and in a study conducted on Alzheimer's model in mice, chronically administered quercetin improved memory in elderly subjects without impairing locomotor activity [58]. This flavonoid exerts a neuroprotective effect on ischemia and reperfusion-induced brain damage and in focal ischemia model [59, 60], improving the biochemical and behavioral effects of stress [61, 62] and high dose may cause sedative effect [63]. Its positive effects on diabetic neuropathy have also been demonstrated [64].

The effect of quercetin as an analgesic has been demonstrated in alcoholic neuropathy model, the results showed that quercetin attenuated allodynia and reduced hyperalgesia [65]. In spared nerve injury rat model quercetin attenuated mechanical allodynia and suppressed the development of neuropathic pain [66]. The effect of quercetin on diabetic neuropathic pain in the DRG have been evaluate, the data showed that thermal withdrawal latency and mechanical withdrawal threshold were higher in the rats treated with quercetin and P2X₄ expression was inhibited and for HEK293 cells transfected with P2X₄ receptors the findings demonstrated that quercetin inhibited ATP-activated current, decrease upregulation of P2X₄ receptor in DRG [51].

2.2. Pain

The International Association for the Study of Pain (IASP) defines pain as "an unpleasant sensory and emotional experience associated with actual or potential tissue damage or described in terms of such damage". The perception of acute pain is a vital protective function for the body of humans and animals to prevent any tissue damage. However, if the pain persists for a long time, the quality of daily life is impaired. About 20% of world's population suffers from chronic pain, usually caused by tissue damage, surgery, tumors or systemic diseases, such as Diabetes [67, 68], One aspect of chronic pain is neuropathic pain, It is caused by direct nerve damage or dysfunction. It is described as stabbing, burning and predominantly persistent pain, without any inflammation or tissue damage at the innervation area. Conditions of allodynia (a non-painful stimulus is perceived as painful) and hyperalgesia (a mildly painful stimulus causes much greater pain) arise [69]. Many of these patients receive only inadequate treatment, as non-steroidal anti-inflammatory drugs and opioids usually do not have a sufficient effect, or due to the increasing side effects cannot use sufficiently high doses [70, 71].

2.2.1. Classification of pain

Pain is one of the main causes of consultation in the doctor. Studies show that chronic pain affects approximately 20% of the world's population, with a higher incidence in the elderly (33%) [72]. Thus, pain, including pathological pain is considered a major social problem, with a significant economic cost.

2.2.1.1. According to the duration

Pain can be classified according to duration; acute, chronic, etc. Acute pain is considered a wake-up call for the body, which helps to plan an appropriate response.

thus, it ensures the physical integrity of the organisms. it is limited in time and disappear with the resolution of the pathological process. As a result, individuals, human or animal, with congenital diseases that prevent the development of pain, or nociception, have serious lesions that limit their survival [73].

In contrast, chronic pain persists for 3-6 months, by definition of IASP the chronic pain is "pain which has persisted beyond normal tissue healing time" As a result, they lose their productive value and become disabled. Chronic pain is often associated with other pathologies such as depression, cognitive problems, sleep disorders. Clinically, social status, mental health, and patient history are also likely to influence the onset and maintenance of chronic pain [74].

2.2.1.2. According to the mechanism

The etiology of pain syndrome is very varied. It can be classified according to the mechanism such as:

2.2.1.1.1. Pain due to excessive nociception

These types of pain emerge by excessive stimulation of the nociceptors. According to the IASP, a nociceptive stimulus is a "stimulus capable of inducing tissue injury". There are nociceptive stimuli of thermal, mechanical, and chemical origin. The stimulation of the nociceptors activates durably the ways of the pain. It includes post-traumatic, post-operative, dental and rheumatic pains.

2.2.1.1.2. Neuropathic pain

According to the IASP "The pain caused by a lesion or disease of the somatosensory nervous system" is called neuropathic pain. These lesions may be due to compression, transection, infiltration, ischemia or neuronal metabolic injury or a combination of these mechanisms. Depending on the location of the lesion or disease neuropathic pain could be of central or peripheral origin [75]. The peripheral includes diabetic peripheral neuropathy, postherpetic neuralgia, antineoplastic or Human Immunodeficiency Virus sensory neuropathy, tumor infiltration neuropathy, phantom limb pain, post-mastectomy pain, complex regional pain syndromes (reflex sympathetic dystrophy) and trigeminal neuralgia. The central cause syndromes include multiple sclerosis, spinal cord injury, central post-stroke pain and Parkinson's Disease. This type of pain is the most common chronic pain and said to be complex because of the pathophysiological changes that could affect normal function and pathology of the

nerves leading to incorrect signal transmission. The neuropathic prevalence ranging from 1% to 8% of the population according to the study [76].

Neuropathic pain, different from nociceptive pain, it does not signal imminent danger, it is a late response that is no longer acute, but it is expressed as painful sensation (Table 2.1). Sensory neurons injured by trauma or medications produce spontaneous discharges that lead to sustained levels of excitability, causing peripheral sensitization with widening of painful impulses and leading to greater release of neurotransmitters causing an increase in the response of spinal cord neurons (central sensitization). It is a process known as "windup".

Its main symptoms are spontaneous pain, hyperalgesia, and allodynia (Table2.1). Spontaneous pains are pains produced without stimulation. Hyperalgesia is an increase in sensitivity to nociceptive stimuli. Allodynia is a painful sensation produced by a painless stimulus. In humans, these pains are secondary to cancers, diabetes, or trauma, and they often evolve towards resistance to current pharmacological treatments.

Table 2.1. *Symptoms and sensitive signs in neuropathic pain [77]*

Symptom or sign	Description
Hyperalgesia	Increased sensitivity to painful stimuli
Allodynia	Pain caused by non-painful stimulation. Can be mechanical, dynamic, thermal.
Anesthesia	Loss of normal sensitivity in the affected region
Dysesthesia	An unpleasant abnormal Sensation, spontaneous or provoked
Hyperpathy	Exaggerated and late response to a harmful stimulus in the affected region.
Hypoesthesia	Reduction of normal sensitivity in the affected region
Paresthesia	Spontaneous abnormal sensation not painful

Most of the experimental models described below were conducted in rats and developed from traumatic, metabolic or toxic peripheral injury [78]. In relation to traumatic injuries, there are currently three models of neuropathic pain in rats that are in widespread use. The first one is chronic constriction injury [79]. It includes the placement of four chrome-plated ligatures on the sciatic nerve. Allodynia, hyperalgesia, and possibly spontaneous pain (dysesthesia) were produced. There have been advances

in understanding the mechanism of neuropathic pain in human. The second one is partial sciatic nerve ligation [80]. Part of the sciatic nerve is tightened by a loop. Mechanical and thermal hyperalgesia was produced and served as a model for causalgiform quality syndrome and sympathetic maintenance pain. The third one is spinal nerve ligation, optimized by Kim and Chung in 1992. One or more spinal nerves that go to the paw are tightened by loop and cut. Long-lasting hyperalgesia was produced in harmful heat at least for 5 weeks.

The presence of allodynia generally indicates neuropathic injury; therefore, it is an important symptom to define a diagnosis of nervous system impairment.

Other methods include intraperitoneal injection of STZ to mimic diabetic neuropathy, or paclitaxel and vincristine or oxaliplatin for chemotherapy induced neuropathy. These are known for the main adverse effect that is the occurrence of peripheral sensitive neuropathy. In this sense, several authors have demonstrated this effect through experimental animal models in order to study the mechanism by which this effect appear [81]. Regarding oxaliplatin-induced neuropathy is still poorly studied at the experimental level, with view animal models for its study. The first model was developed in 2007 on rats [82], where they administered oxaliplatin in doses of (1.2 or 4 mg/kg, i.p), twice a week for four and a half consecutive weeks and evaluated with behavioral tests through the drugs used to treat neuropathy, such as carbamazepine, gabapentin, local anesthetics, calcium chloride and magnesium chloride [83]. Models for central pain use contusion (trauma using the force of impact with tissue displacement), or ischemic injuries due to slow compression through clamping or balloon inflation. Cytotoxic methods employ the injection of glutamate (kainite) analogs or substances that allow the injury of specific places of the gray substances. The techniques described aim to cause mechanical and thermal hyperalgesia [84, 85]

2.2.1.1.3. *Inflammatory pain*

The onset of inflammatory processes is followed by an increase in the sensitivity of nociceptive neurons, which causes so-called inflammatory pain [86]. It may be secondary to tissue damage or tumorigenesis processes, and it results from the combined actions of proinflammatory molecules, such as cytokines, chemokines, neuropeptides and prostaglandins, which modify the properties of the receptors and ion channels involved in nociception at the peripheral and central levels, thus causing hypersensitivity state [87].

2.2.1.1.4. *Dysfunctional pain*

It is related to a dysfunction of the pain control systems without a lesion being associated with it. Pathologies, such as fibromyalgia, irritable bowel syndrome or tension headache, are the cause of these dysfunctional pains. They are caused by dysfunction in the endogenous pain inhibition mechanisms [88]. While pharmacological treatments remain very ineffective against these types of pain, treatments based on non-pharmacological approaches are sometimes more effective or suitable.

2.2.2. Neuroanatomy and physiology of pain perception

Pain-inducing signals are perceived via free nerve endings in the skin, converted into APs, and transmitted to the brain via the spinal cord through successive neurons and their axons (Figure 2.5). This process is commonly referred to as nociception. The cell bodies of these primary afferents of the skin are located in the spinal ganglia in the spinal canal. They are referred to as pseudounipolar nerve cells, since they have apparently only one extension at the perikaryon, but these are actually two extensions, of which one branch leads into the periphery (skin) and a second branch into the dorsal horn of the spinal cord [89]. In the gray matter of the central nervous system, the signal is transmitted via a synapse to a second-order neuron whose axon runs on the contralateral side of the spinal cord to the nuclei in the thalamus. From there, third-order neurons relay the signal to various brain cortex regions. Only then is the signal processed and perceived as "pain" [90, 91]. The pain stimuli triggered in the skin are processed and localized among other things in the postcentral gyrus.

Skin afferents nature and receptor type play a huge role in their stimulation whether by mechanical, thermal, and chemical stimuli and therefore can be distinguished accordingly. Also, the intensity of the stimulus needed to evoke a response plays a role. Mechanoreceptor and thermoreceptors transmit harmless stimuli, whereas nociceptors respond to stronger, painful and potentially tissue-damaging stimuli [89].

The associated conductive fibers of the free nerve endings vary morphologically and functionally, according to their size, myelination, and the rate of conduction. The $A\alpha / \beta$ fibers are the largest fibers. They show a high degree of myelination and lead APs the fastest. $A\delta$ fibers are smaller, thinner myelinated and conduct at a medium velocity (> 2 m/s). The thinnest fibers are the unmyelinated C fibers. They lead slowly (< 2 m/s) and are mainly associated with late, "blunt" pain [92, 93]. The nociceptors

described above transmit their signals mainly via C fibers, but also via some A δ fibers [91, 94].

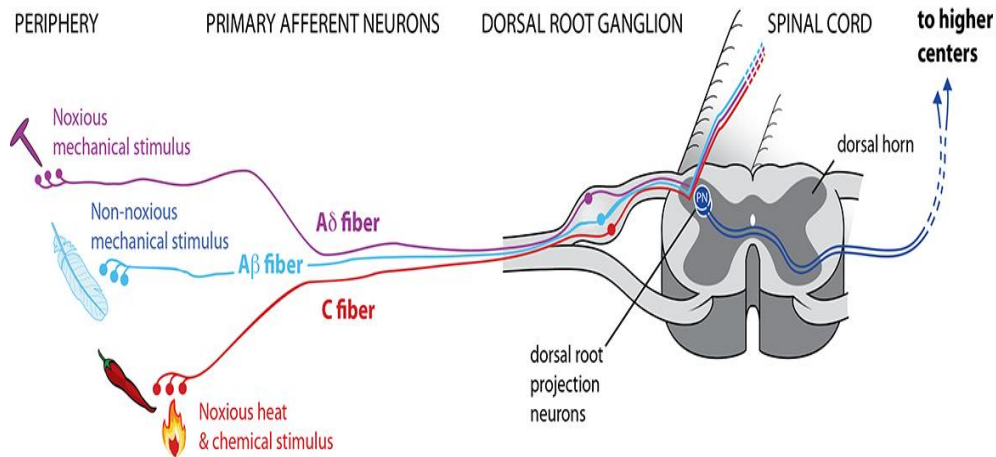

Figure 2.5. Neuroanatomy of nociception and the fibers carrying pain sensation [95]

The groups of nociceptors are very heterogeneous and can be divided into other subgroups. The ability to form and secrete peptides, as well as the expression of certain ion channels, receptors, or other surface proteins, characterizes these subgroups. C-fiber conductive nociceptors may be classified as a "peptidergic" and a "non-peptidergic" population. "Peptidergic" nociceptors have the ability to form and secrete peptides [92, 93, 96]. Substance P, a neurotransmitter, and calcitonin gene-related protein (CGRP), a potent vasodilator, are neuropeptides known to be produced by peptidergic nociceptors. In addition, they express tropomyosin receptor kinase A, which is a high affinity receptor for nerve growth factor (NGF), a growth factor indispensable for the development and differentiation as well as the survival of prenatal neurons [97, 98].

"Non-peptidergic" C-fiber nociceptors lack the ability to secrete peptides [89, 99]. These nociceptors are comparatively small and have a high affinity for isolectin B4 (IB4), a lectin from the species *Griffonia simplicifolia*, which binds to α -D-galactose molecules [100, 101].

Nociceptors also express certain ion channels, such as Transient Receptor Potential Vanilloid 1 (TRPV1) and Nav1.8, to which various functions in pain generation are attributed [102]. TRPV1 is a heat-sensitive calcium channel that is sensitive to temperatures above 42 °C and capsaicin, an ingredient of chili peppers. After appropriate stimulation, the influx of divalent cations such as Ca²⁺ leads to

depolarization of the cell membrane and thus to the development of an AP [103]. Nav1.8 belongs to the tetrodotoxin-resistant, voltage-dependent Na⁺ channels, which are particularly important for the transmission of APs and thus of the nociceptive signal [94, 99]. It was also shown In 2014 that RII β , a regulatory subunit of PKA, is nearly exclusively expressed in all nociceptive neurons [104]. Neurofilament 200 can be used to immunocytochemically differentiate the unmyelinated C-fiber nociceptors from myelinated A δ neurons, since it is the heaviest neurofilament at 200 kDa and is therefore detectable above all in the cytoskeleton of stronger myelinated neurons [94, 105, 106].

The cell bodies of the primary afferents lie in the DRG. Based on their isolation, numerous findings have already been gained on the structure and function of the nociceptors. To determine the composition of this heterogeneous group of neurons, antibodies can be used for the proteins. However, many neurons have a polymodality, so that they can be stimulated by several types of stimulation such as: Blood pressure and heat are activated. Moreover, this polymodality partly reflects in the composition of its immunocytochemical "marker proteins". Multiple marker proteins are often express by neurons and the majority of these marker proteins are often expressed by several subgroups. Nevertheless, it is still possible to identify and characterize subgroups based on the density and distribution of their expression [89, 91, 107].

Table 2.2. Classification of the peripheral nerve fibers.

Fiber type	function	Mean fiber diameter (μm)	Line speed (m/s)
A α	Primary muscle spindle afferents, motor to skeletal muscles	15	70-120
A β	Skin afferents for touch and pressure	8	30-70
A γ	Motorized to muscle spindles	5	15-30
A δ	Skin afferents for temperature and nociception	≤ 3	12-30
B	Sympathetic preganglionic efferent	3	3-15
C	Skin afferents for nociception, sympathetic postganglionic efferent	1	0.3-2

2.2.3. Modulation of pain sensitivity

The perception of pain in the brain by the signal of a nociceptor always requires a triggering stimulus that exceeds a certain threshold at the free nerve end and thus triggers an AP. However, this threshold is not static but can be modulated by numerous influences in each nociceptor [108, 109]. A reduction in the threshold is referred to as sensitization. Such influence may be a prior mechanical or thermal stimulus, or even a chemical substance exogenous or endogenous, e.g., was increasingly formed in the context of an inflammatory reaction. This peripheral sensitization lowers the threshold of nociceptors and weaker, usually harmless stimuli can lead to the development of an AP. It comes to allodynia and hyperalgesia [89].

This state can serve as a warning mechanism in the body, for example, if an injured body site should be spared, so as not to interfere with the healing process. However, if hyperalgesia persists for longer, it may lead to chronic pain, which cannot be adequately treated and gradually leads to an impairment of the quality of life of the affected person.

However, pain sensitivity can be altered not only by changes in peripheral tissue but also by the nociceptors themselves. When nerve fibers are damaged by a trauma, virus or metabolic changes such as diabetes, they are able to transport even peptides such as CGRP and substance P in the periphery and secrete them, causing neurogenic inflammation [110, 111]. In addition, there are intracellular changes, which among other things lead to an upregulation of ion channels and receptors, which makes the nerve more sensitive.

However, the intracellular mechanisms of sensitization are not fully understood. It is known inter alia that some inflammatory mediators (e.g. prostacyclin) by binding to corresponding receptors for the activation of adenylate cyclase and thus to the release of the secondary messenger cyclic adenosine monophosphate (cAMP) in nociceptors [112, 113]. The released cAMP activates PKA, which then phosphorylates ion channels, thus altering their likelihood of opening. By doing this, the neuronal excitability, and the transmission of APs along the axons can be modulated. The activity of PKA has been shown to be increased in sensitized neurons and by inhibition with specific inhibitors, hyperalgesia can be reduced [114–116].

Extracellular signal-regulated kinase 1/2 (ERK1/2) is also believed to play a key role in sensitizing nerve cells. In addition to the signaling pathways via PKA and

protein kinase C, the signaling pathway to ERK1/2 could be observed as another, independent pathway for sensitizing the neurons, although the target proteins regulated by it remain largely unclear [117]. After stimulation of membrane-bound tyrosine kinases by growth factors or cytokines from the peripheral tissue, various signaling pathways lead to phosphorylation and thus activation of ERK1/2 [118]. In this way, For example, epinephrine stimulate the phosphorylation of ERK1/2 in neurons of the DRG via a PKA-independent signaling pathway leads to hyperalgesia [117]. This can be reduced again by inhibiting individual components of the signal path to ERK1/2. A direct, painful stimulation of the nociceptors also leads to increased ERK1/2-phosphorylation in the neurons in the animal model [119, 120].

Application of NGF also leads to pain sensitization and also activates ERK1/2 in this context [121–123]. Likewise, after ligature of the sciatic nerve, increased ERK1/2 phosphorylation could be measured leading to neuropathic pain [124]. This resulting hyperalgesia can be correspondingly reduced by specific inhibition of ERK1/2 phosphorylation [125], which is why the pain-inducing ERK1/2 signaling pathway is also discussed as a therapeutic approach to the treatment of neuropathic pain [119, 126, 127].

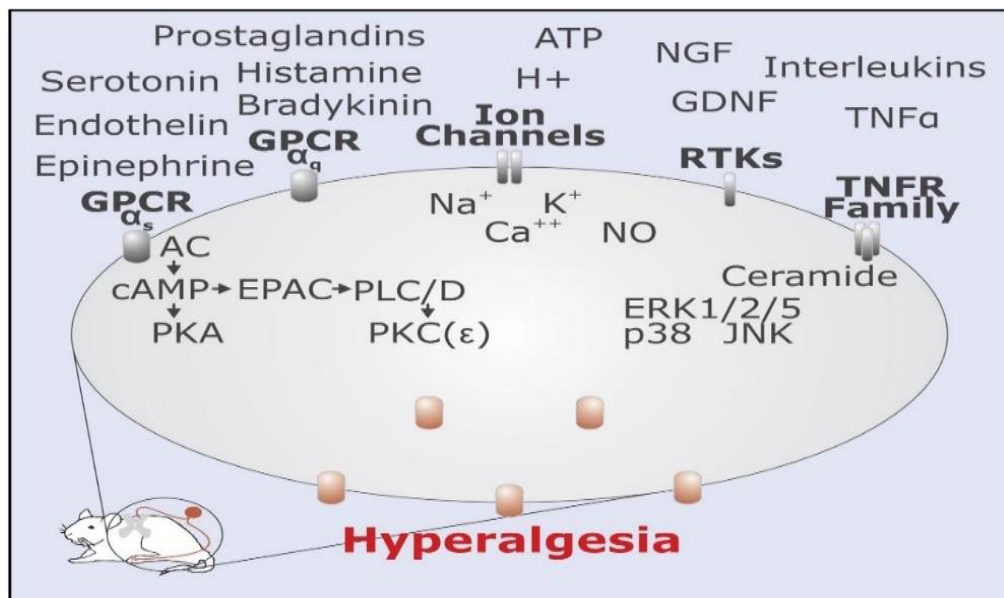

Figure 2.6. Modulation of pain sensitivity and signaling components in nociceptor [154]

2.3. DRG

2.3.1. Anatomy of DRG neurons and clinical significance

The DRG (spinal ganglia) of the rat are located as a section of the posterior root on the foramina spinalia near the bony canalis vertebralis within the dura mater. They are surrounded by a connective tissue capsule, the perineurium, and traversed by vascular connective tissue. The ganglion neurons are the first neurons of the afferent sensory fibers. So, the peripheral nervous system is composed of 31 pairs of DRG, each consisting of thousands of DRG neurons, located outside the blood-brain barrier. Anatomically speaking, the archetypal neuron is composed of three different parts : 1) Axon, chemically distinguished transport branch; 2) dendrite, receiving branch; And 3) the cell body, the predominant site for protein synthesis and responsible for the distribution of proteins, especially ion channels [89]. However, DRG neurons are different, because they are pseudounipolar, which means that the short axon divides into two branches: 1) centrally terminated branch, which forms the axon and extends to the dorsal horn; And 2) peripherally terminated branch, which forms dendrites and extends to the periphery [89, 128].

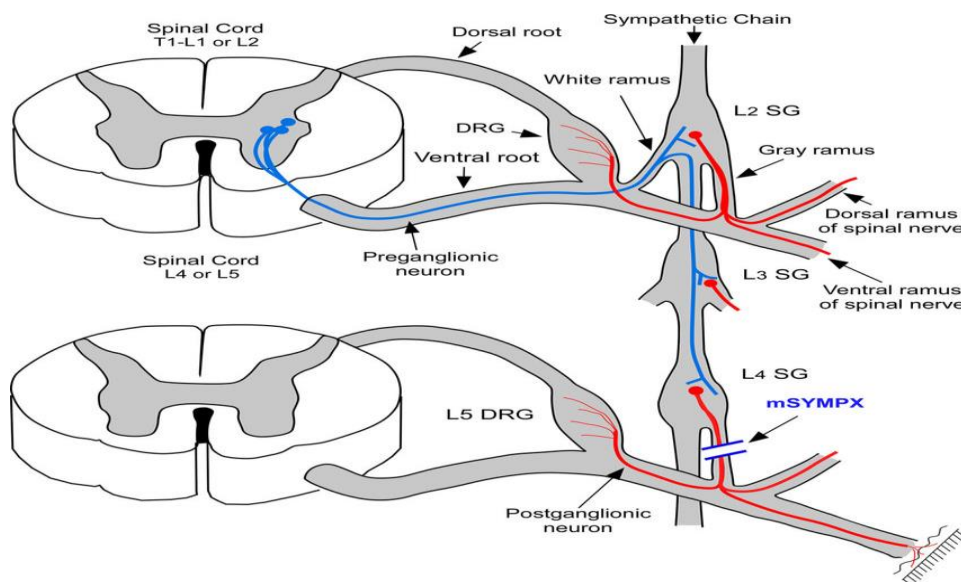

Figure 2.7. DRG neurons as part of the reflex arc

DRG neurons respond to various stimuli and which are normally inactive in the absence of the stimulus. when there is a stimulus, APs are generated in DRG neurons and the dorsal root of the spinal cord is the first signal processing station.

2.3.2. Ion channels in DRG

2.3.2.1. Sodium channels

In the pain-conducting C-fibers of the DRG neurons, voltage-gated Na⁺ channels (Nav) account for a large proportion of the currents responsible for depolarization after stimulation and for the transmission of APs and consist of 9 subunits from Nav1.1 to Nav1.9. These Nav channels are also of great importance in the development of pain signals, can be classified according to their sensitivity to tetrodotoxin: tetrodotoxin resistant or tetrodotoxin sensitive. In humans, loss-of-function mutations in the Nav1.7 channel, which cause total insensibility to pain [73]. Null mutations of Nav1.7 lead to the loss of large sensory fibers and thus also to the inability to experience pain [129]. Mutation of other Nav channels may also lead to the loss of pain perception, as Leipold and colleagues showed in their study on Nav1.9 channel [130].

2.3.2.2. Potassium channels

K⁺ channels are mainly responsible for the depolarization and fall of the AP, restoring the membrane potential to the resting state. There are four different main types of K⁺ channels: voltage-gated, Ca²⁺ activated, inward rectifier, and two pores K⁺ channels [105].

The voltage gated channels are formed from families K_v1 to K_v12 [105], In rat models of neuropathic pain, k_v7 family activators showed analgesic effect [131, 132] but these agents failed in clinical trials [133]. The Ca²⁺ activated channels comprise K_{Ca}1– K_{Ca}8, whereas the inward rectifier family is composed of K_{ir}1– K_{ir}7, two of which K_{ir}3 and K_{ir}6 are mainly responsible for nociception. Hypersensitivity, especially to heat, has been noticed when a specific knockout of K_{ir}3.1 and K_{ir}3.2 was established in CNS of normal animals [134]. Finally, the two-pore family is composed of K_{2p}1 – K_{2p}14, however, the physiological functions of the majority of this group remain unknown [105].

2.3.2.3. Calcium channels

The voltage-gated calcium channels, particularly T-type, have been associated with chronic pain. T-Type antagonists injected intra-peritoneally or locally have been shown to mitigate acute and chronic pain behaviors[135].

2.3.2.4. TRP channels

Members of the non-selective TRP channels are also strongly expressed in DRG neurons and divided into 6 different subfamilies. Capsicum from the chili plant, menthol from mint, and mustard oil (allyl isothiocyanate) stimulate the non-selective cation channels TRPV1, TRPM8, and TRPA1 cause sensations such as burning, cold, and even acute pain [89]. TRPV1 channels are expressed in the small, pain-conducting C-fibers of the DRG neurons and, in addition to temperatures above 45°C, can also be activated by chemical substances and acidic environments such as that occurring in inflammation [136]. The TRPA1 channel plays a critical role in inflammation, both as a detector and initiator of inflammatory responses [137]. In addition to pain, TRPA1 is also known as a sensor for stimulants, cold, and stretching with TRPV1 expressed in C-type pain fibers [138–140]. Activation of both Nav channels and TRP receptors results in depolarization of the neuron, which leads to neuronal excitement and ultimately can cause pain.

2.4. Electrophysiology

2.4.1. The resting potential

Excitable cells have a resting potential based on different ionic compositions of the extra and intracellular space. K⁺ is the most abundant intracellular ion, while Na⁺ predominates in the extracellular space. The resting potential is largely a K⁺ diffusion potential and is primarily determined by the concentration gradient of K⁺ across the membrane. Nerve cells have a resting potential of -70 to -90 mV. Ion gradients are built up across the cell membrane through energy-consuming transport mechanisms that move ions against their electrochemical gradients. The uneven distribution of ions due to the Na⁺, K⁺ pump, which transports Na⁺ ions out of the cell and K⁺ ions into the cell. The gradient built up in this way would even out through diffusion. Since the displacement of charged particles creates an electric field that counteracts the diffusion pressure, an equilibrium between electrical and chemical gradients is ultimately created. Negatively charged intracellular proteins cannot cross the double lipid membrane, so negative charges remain inside the cell. The equilibrium potential (EG) can be determined for individual ions using the Nernst equation:

$$EG = \frac{R.T}{F.Z} \cdot \ln \left(\frac{[Ion]_{outside}}{[Ion]_{inside}} \right) \quad (2.1)$$

EG = equilibrium potential of the ion (V)

R = general gas constant 8.31451 (J.mol⁻¹ .K⁻¹)

F = Faraday constant 9.6485 (C .mol⁻¹)

T = temperature (K)

z = valence of the ion

This results in an equilibrium potential of +67.5 mV for Na⁺ and -84.7 mV for K⁺ at room temperature (T = 23 °C) if the following ion concentrations are used as a basis for the DRG cell: [Na⁺_i]: 10 mmol / l, [Na⁺_a]: 141 mmol / l,

[K⁺_i]: 155 mmol / l, [K⁺_a]: 5.6 mmol / l

This results in an inward direction for Na⁺ ions and an outward direction for K⁺ ions. The ion imbalance provides the potential energy for pulse transmission. Nerve impulses are transmitted as APs [141, 142].

2.4.2. The AP

An AP is understood to be the rapid depolarization from the resting potential to positive potentials, which automatically repolarize to the resting potential with the time course typical for the cell type. The AP has a positive peak value of about +60 mV, the duration for this is approximately 1 ms for the nerve. In the spread phase, the rapid positive change in potential begins due to increased Na⁺ conductivity. As a result, the membrane potential briefly approaches Na⁺ equilibrium potential. During depolarization, the K⁺ conductivity increases with a delay, which initiates the repolarization with the K⁺ outflow. After an AP, the membrane appears to be non-excitabile for about 2 ms. In this absolute refractory phase, the Na⁺ channel system is still inactivated. During the following phase, the cell is relatively refractory; only strong depolarizations can trigger potentials of reduced amplitude [143].

2.4.3. The conduction of excitation

Due to the influx of Na⁺ at the AP, a direct membrane discharge is also achieved in neighboring axon regions. After reaching the threshold, further APs and thus transmission of the excitement can be evoked. Fiber diameter, membrane resistance, and membrane capacity affect the electrotonic propagation and thus the conduction velocity. C fibers, non-myelinated skin fractions of the nociceptors, reach a fiber diameter of 1 μm and achieve a conduction speed of about 1 m / s. The myelinated Aα fibers (approximately 15 μm in diameter), which function as primary muscle spindle afferents, conduct much faster (approximately 100 m/s). The medullary sheaths act as

insulators on such fibers. The myelin sheath is interrupted at a distance of 1-2 mm, and the membrane is exposed on these Ranvier nodes. Here the AP jumps from node to node; this type of excitation conduction is also referred to as saltatory conduction [144].

3. MATERIALS AND METHOD

3.1. Materials

All standard chemicals (quercetin, GA, and RA) were obtained from Sigma-Aldrich. A stock solution of these substances were prepared in dimethylsulphoxide (DMSO) 100% and stored at 4°C. Final required concentration of all drugs were made up fresh daily in extracellular solution (pH 7.4), where the ratio of DMSO is less than 0.3% [145].

3.2. The Patch-Clamp Technique

The experiments of this work were carried out with the help of the patch-clamp technique, the principle of which is a close contact between a glass pipette and a cell. For this purpose, a tapered glass pipette with a tip diameter of around 1 μm is moved to a cell membrane under a microscopic view. A part of the cell membrane is sucked in by negative pressure into the pipette. A mechanically and electrically stable state is achieved which, under optimal conditions, is reflected in a sealing resistance of several giga-ohms (gigaseal).

This technology has two advantages over conventional microelectrode technology. The current of injury of the cell becomes negligibly small, i.e., the current does not flow through a current leak, but through the cell membrane to be examined. The electrical noise, which is inversely proportional to the sealing resistance, is so small that currents through individual ion channels can be measured.

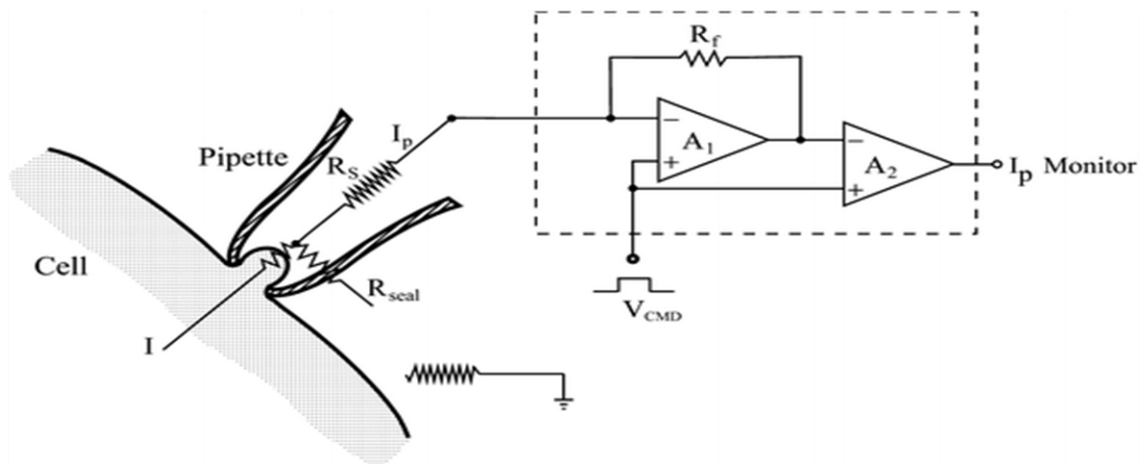

Figure 3.1. Schematic representation of a patch-clamp arrangement in a whole-cell configuration [142]

To measure the flowing ions, an electrical amplifier is needed to measure the potential of the membrane patch underneath a pipette and constantly compares it with a previously selected target value. By supplying power accordingly, it compensates for the difference between the actual value and the setpoint value, so that the potential at the membrane is kept constant. This principle is called a voltage-clamp [146]. The required power supply corresponds to the change in conductivity of the membrane patch and is an expression of the openings and closings of the ion channels located here. The clamping currents therefore reflect the ion currents flowing through the membrane at a given potential.

With suitable equipment, the amplifier enables a compensation of the capacitive currents and leakage currents of the cells during the experiment and a compensation of the series resistances by 80-90%.

Depending on the problem, different configurations can be created with the patch-clamp method: Intact cells (cell-attached and whole-cell) as well as membrane sections, so-called cell-free patches, can be examined.

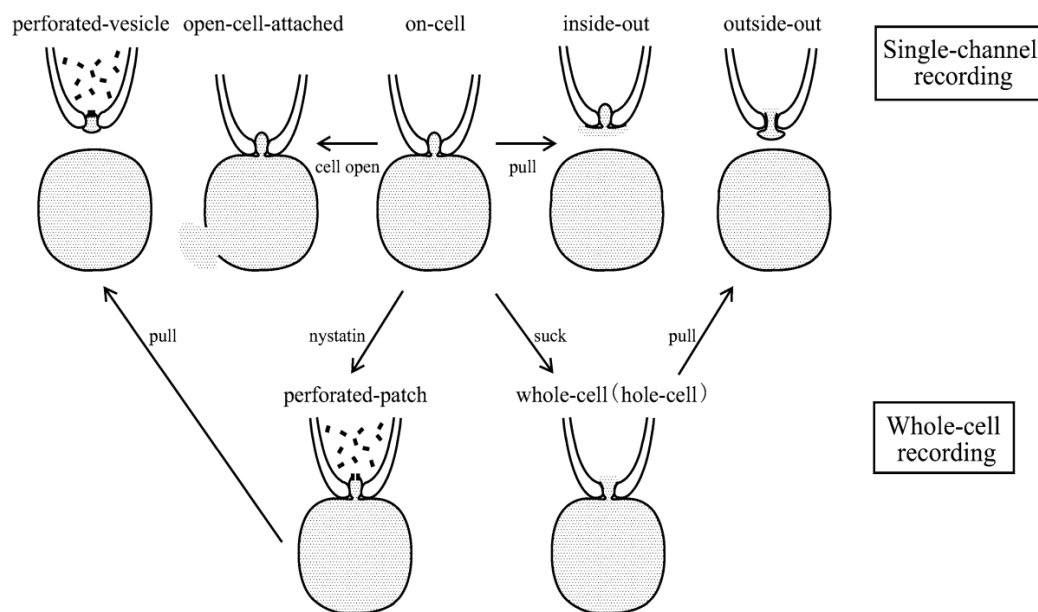

Figure 3.2. Schematic representation of various patch configurations [142]

The cell-attached method isolates the membrane section below the pipette. The membrane under the pipette is removed by suction and access to the entire cell interior (whole cell) is gained. In the case of cell-free patches, an attempt is made to detach the circumscribed membrane patch that lies under the pipette from the rest of the cell. The

possibilities of the inside-out and the outside-out configuration arise here. The inside-out patch is created by quickly withdrawing the patch pipette after a tight cell contact. The detachment of the membrane section means that the former inside of the cell now faces the bath side. When the pipette is slowly withdrawn, a ridge forms between the pipette and the remaining cell. This breaks off the lipid bilayer membrane closes and the physiological outside remains facing the bath solution (outside out) [147].

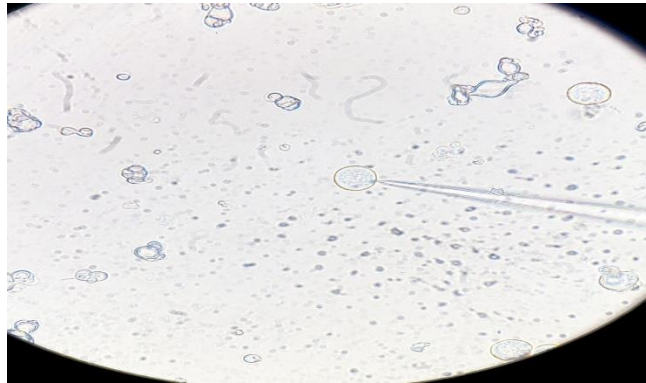

Figure 3.3. Photo of a pipette and DRG cell in whole-cell mode (40x magnification).

3.3. Animals

Sprague Dawley male rats weighing 150-200 g and 8-12 weeks old were used. Animals housed in well-ventilated rooms at 25 ± 1 °C, set to 12 hours light and 12 hours dark cycle and relative humidity ($54 \pm 5\%$). Standard feed pellets and tap water were given for feeding purposes.

Ethics Committee Approval was obtained from Anadolu University (Decision No: 2021-15, Appendix I)

3.4. DRG dissection

The animal was anesthetized with mixture of ketamine and xylazine as a ratio of 90 mg/kg to 10 mg/kg respectively and the animals injected with 1ml/ kg (i.p.) [148], after 5 -8 minutes when the animal was totally anesthetized the decapitation was performed, then the back skin incised. The vertebral column was removed and kept for 5 minutes in a falcon tube that contains cold PBS, the following work is done under the laminar flow cabinet. The vertebral column is placed in petri dish contain Dulbecco's Modified Eagle's Medium (DMEM) solution at 4 °C and cutted into two symmetrical parts from the midline by using iris scissor. The spinal cord was removed carefully and harvesting of the DRG is started by using hairspring tweezer, the harvested DRGs are

placed in a Petri dish containing DMEM and penicillin- streptomycin, after harvesting all the cells cleaning the DRG from projections and attached tissues was carried out using surgical lancet, and the cells were moved to a Eppendorf tube that contains 2 mg of collagenase type IV (sigma) in 1 ml of DMEM and pen-strep and keep in incubator at 37 C° with 95% O₂ and 5% CO₂ for 45 minutes with the mouth of Eppendorf tube open and shaking the tube every 10 minutes. The supernatant was taken, and the cells were washed by PBS three times with centrifugation for 30 seconds and removing the supernatant in each time. After that 100 µl of 0.25% trypsin+EDTA was added to the cells with 1 ml of DMEM+Pen-Strep and incubate for 6 minutes with shaking the tube every 3 minutes. After 6 minutes the cells were washed by DMEM 3 times with centrifugation for 45 to 60 second and supernatant was discarded in each wash. Then 1 ml of DMEM was added to the cells in Eppendorf tube and the cells were moved to a 15 ml falcon tube that contains 1 ml of DMEM, so the sum of solution is 2 ml. After that the pipetting started gently for 5 minutes as a rate 4 times per minute with blue tip cutted pipette and then for another 5 minutes with non-cut blue tip pipette and finally the cells passed through insulin syringe 3 times very slowly. The final step is suspending the cells in solution of DMEM + pen-strep + FBS as 12.5 ml for 1 ml of the cells, after 1 to 2 hour the cells becomes ready to work on [149, 150].

3.5. Electrophysiology

3.5.1. Voltage-clamp recordings

Voltage-clamp recordings were conducted in whole-cell voltage-clamp configuration to record ion currents from acutely dissociated DRG cells, at room temperature, bathed in external solution (in mM) (NaCl 140, KCl 3, MgCl₂ 1, CaCl₂ 1, glucose 10 and HEPES ACID 10. pH adjusted to 7.3 using NaOH, 320 mOsm). GΩ-seals were established using Thin Wall Borosilicate Glass pipettes with filament (Sutter Instrument BF150-110-10) filled with the internal solution (KCl 140, NaCl 10, MgCl₂ 2, CaCl₂ 0.1, EGTA 1.1, HEPES ACID 10, D glucose 3, pH 7.2 titrated with KOH, 310 mOsm), for Voltage-clamp recordings micropipette pulled by P-97 Micropipette Puller (Sutter Instrument) to a final pipette resistance of 2-5 MΩ. The passage to whole cell configuration was done using negative pressure applied either by mouth or by use of 1 ml syringe, the passage to whole cell is marked by a big drop in series resistance to around 10 MΩ and increase of membrane capacitance. Recordings were conducted at room temperature.

Depolarizing pulses to 0 mV for 300 ms were used after clamping the membrane potential to -60 mV. The current–voltage relations (IV-curve), was obtained using depolarizing steps of 10 mV increments from -60 mV to +80 mV.

The test chemical was applied after getting a stable outward current in response multiple depolarizing steps to 0 mV.

Currents were recorded using a single headstage version of the Integrated Patch Amplifier (IPA) (Sutter Instrument) and SutterPatch® Data Acquisition and Analysis Software (SutterPatch 2.0.4) installed on Windows®10 and used in voltage-clamp mode. Data were sampled at 25 kHz and filtered at 5kHz using the built-in filter of the IPA. Electrode compensation and series resistance compensation were automatically applied using the automatic compensation option in the software. Data were analyzed used the same software (SutterPatch 2.0.4).

3.5.2. Current-clamp recordings

Current-clamp recordings were conducted in whole cell configuration to record variation in the voltage of acutely dissociated DRG cells. The cells were bathed in external solution (in mM) (NaCl 140, KCl 5, CaCl₂ 2.5, MgCl₂ 1.2, HEPES ACID 10, D-glucose 10 (pH = 7.4 with NaOH, 321 mOsm). GΩ-seals were established using Thin Wall Borosilicate Glass pipettes with filament (Sutter Instrument BF150-110-10) filled with the internal solution (in mM) (KCl 130, NaCl 10, HEPES ACID 10, Mg-ATP 4, EGTA 5, D-glucose 10 (pH = 7.3- 7.4 with KOH, 313 mOsm). For current-clamp recordings micropipette pulled by P-97 Micropipette Puller (Sutter Instrument) to a final pipette resistance of 4-6 MΩ. The passage to whole cell configuration was done using negative pressure applied either by mouth or by use of 1 ml syringe and marked by a big drop in series resistance to around 10 MΩ and increase of membrane capacitance. Recordings were conducted at room temperature.

Data was acquired using in current-clamp mode a single headstage version of the Integrated Patch Amplifier (IPA) (Sutter Instrument) and SutterPatch® Data Acquisition and Analysis Software (SutterPatch 2.0.4) installed on Windows®10. Acquisition sampling rate was 25 kHz and filtered at 5kHz using the built-in filter of the IPA.

Spontaneous firing activity were monitored for few minutes of whole-cell recording. The AP threshold was determined using a depolarizing current step of 10 pA

for 10 mS from 0 pA to 300 pA and the minimum injected current amplitude that elicit an AP was chosen.

APs were elicited for several times using the value obtained, when a stable result is acquired the test chemical is applied and changes in signal are monitored for amplitude, half-width, fast after-hyperpolarization (AHP), APD and medium AHP. Data were analyzed using the same software (SutterPatch 2.0.4).

3.6. Solutions

AP (Current clamp) solution

- Intracellular pipette solution contained (in mM): KCl 130, NaCl 10, HEPES ACID 10, Mg-ATP 4, EGTA 5, D-glucose 10 (pH = 7.3- 7.4 with KOH, 313 mOsm). (all from Wisent, Inc.)

- Extracellular solution composed of (in mM): NaCl 140, KCl 5, CaCl₂ 2.5, MgCl₂ 1.2, HEPES ACID 10, D-glucose 10 (pH = 7.4 with NaOH, 321 mOsm) (all from (Wisent, Inc.)

Voltage clamp recording

- Internal pipette solution contained (in mM): KCl 140, NaCl 10, MgCl₂ 2, CaCl₂ 0.1, EGTA 1.1, HEPES ACID 10, D glucose 3. Adjust pH to 7.2 with KOH. 310 mOsm) (all from Wisent, Inc.)

-Extracellular (bath) solution composed of (in mM): NaCl 140, KCl 3, MgCl₂ 1, CaCl₂ 1, glucose 18 and HEPES ACID 10. Adjust pH to 7.3 using NaOH, 320 mOsm) (all from Wisent, Inc.) [151].

3.7. Statistical Analysis

OriginPro 2012 (64-bit),9.8.0.200 (Learning Edition), copyright ©1991-2020 OriginLab corporation, and GraphPad InStat program also has been used. Electrophysiological data was given as mean ± standard error of the mean. Unpaired Student's t test was used when evaluating the AP. In IV measurements, paired Student's t test and one-way ANOVA procedure was used when necessary (comparisons). A value of $p < 0.05$ was considered significant.

4. RESULTS

4.1. Effect of GA on K⁺ peak current

4.1.1. GA 01 μ M

Effect of 01 μ M GA peak K⁺ current, GA 1 inhibits the peak K⁺ current and maximal conductance by 84.1%, and $V_{1/2}$ shifted to depolarization direction with no significant changes. The curves produced according to Boltzmann fitting equation and calculated based on mean \pm S.E.M.

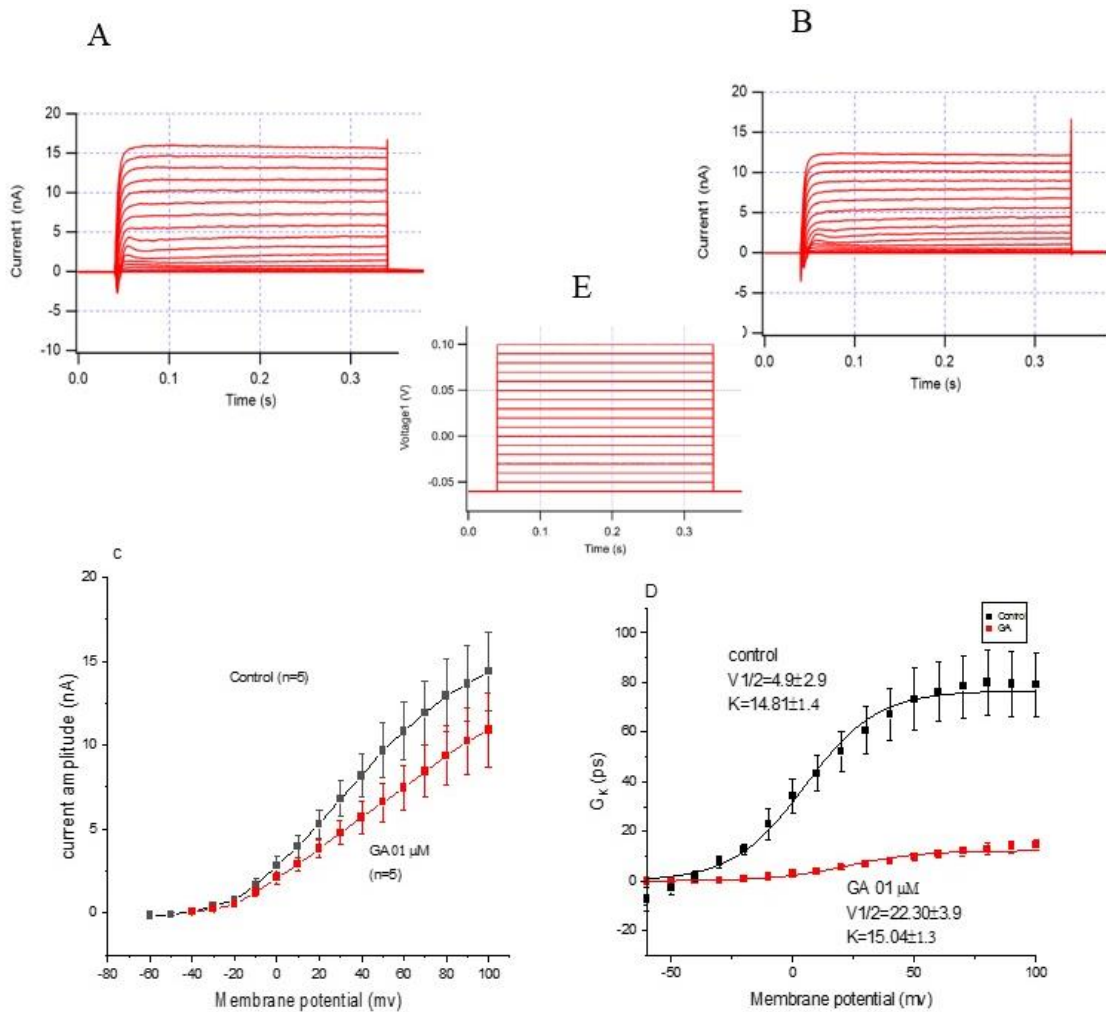

Figure 4.1. K⁺ current in DRG neurons and their modulation by GA 1 μ M. (A) I_K evoked in neurons in response to voltage step protocol; (B) I_K after adding 1 μ M GA; (C) I-V curve; (D) conductance (G_K) curve; (E) steps of the potential to elicit the current. The cells were subjected to changes in the potential ranging from -60 mV to +80 mV in 10 mV increments to cause the currents shown. The conductance decreased significantly ($p < 0.05$) $V_{1/2}$ showed no significant change. ($n = 5$ for control and GA).

4.1.2. GA 10 μM

The effect of 10 μM GA on the I_K and conductance, the maximal conductance decreased by 13.7% and also the K^+ current was suppressed. $V_{1/2}$ insignificantly shifted to the right side.

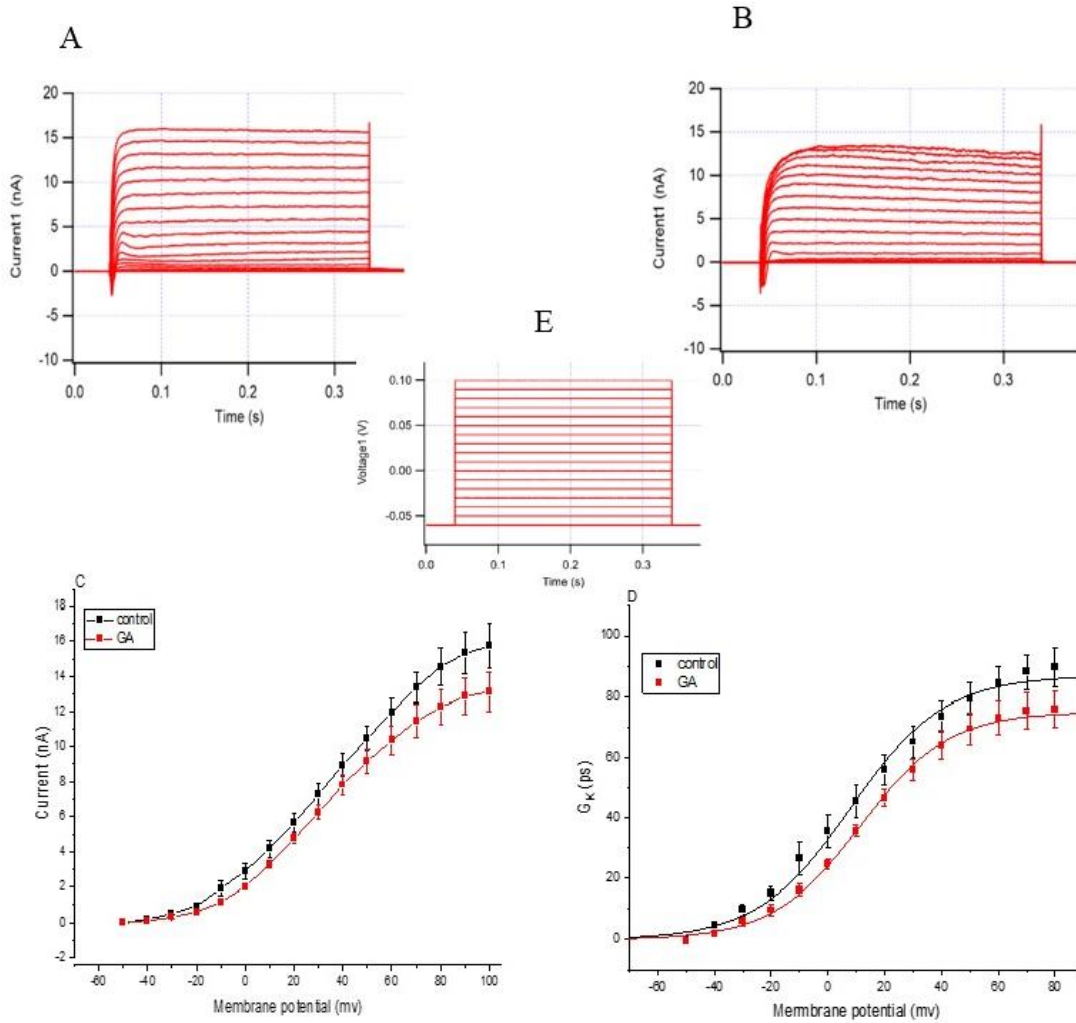

Figure 4.2. K^+ current in DRG neurons and their modulation by GA 10 μM . (A) I_K evoked in neurons in response to voltage step protocol; (B) I_K after adding 10 μM GA; (C) I-V curve; (D) conductance (G_K) curve; (E) steps of the potential to elicit the current. The cells were subjected to changes in the potential ranging from -60 mV to +80 mV in 10 mV increments to cause the currents shown. (for control $V_{1/2}=8.06832 \pm 2.83149$, $k=16.51178 \pm 1.26851$ and $n=6$); for GA 10 μM ($V_{1/2}=11.45019 \pm 2.06803$, $k=15.54674 \pm 1.00238$ and $n=5$). No significantly changes in $V_{1/2}$ ($p>0.05$).

4.1.3. GA 100 μM

The effect of GA 100 μM on the I_K and conductance, the results showed decrease in the maximal conductance by 43.6% and also decrease in the maximum current.

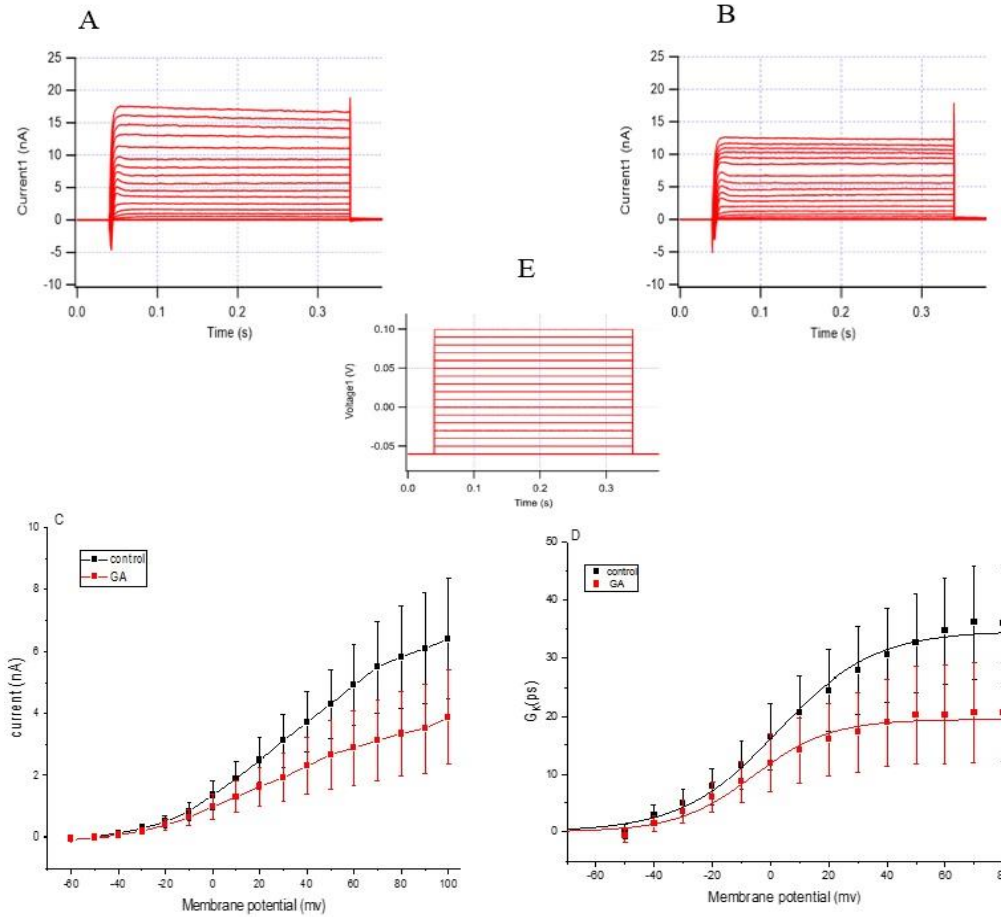

Figure 4.3. K^+ current in DRG neurons and their modulation by GA 100 μM . (A) I_K evoked in neurons in response to voltage step protocol; (B) I_K after adding 100 μM GA; (C) I-V curve; (D) conductance (G_K) curve; (E) steps of the potential to elicit the current. The cells were subjected to changes in the potential ranging from -60 mV to +80 mV in 10 mV increments to cause the currents shown ($V_{1/2} = 2.25345 \pm 3.12153$ and -5.98448 ± 3.85467 ; $K = 16.56659 \pm 1.44861$ and 13.2242 ± 1.9651 for control and GA 100 respectively; $n = 7$ for each). $V_{1/2}$ significantly shifted toward left ($p < 0.05$), the curves produced according to Boltzmann fitting equation and based on mean \pm S.E.M.

4.2. Effect of Quercetin on K^+ peak current

4.2.1. Quercetin 1 μ M

The figures present the effect of 1 μ M quercetin on the I_K and conductance, the maximal conductance reduced by 36.3% and the current inhibited after adding quercetin.

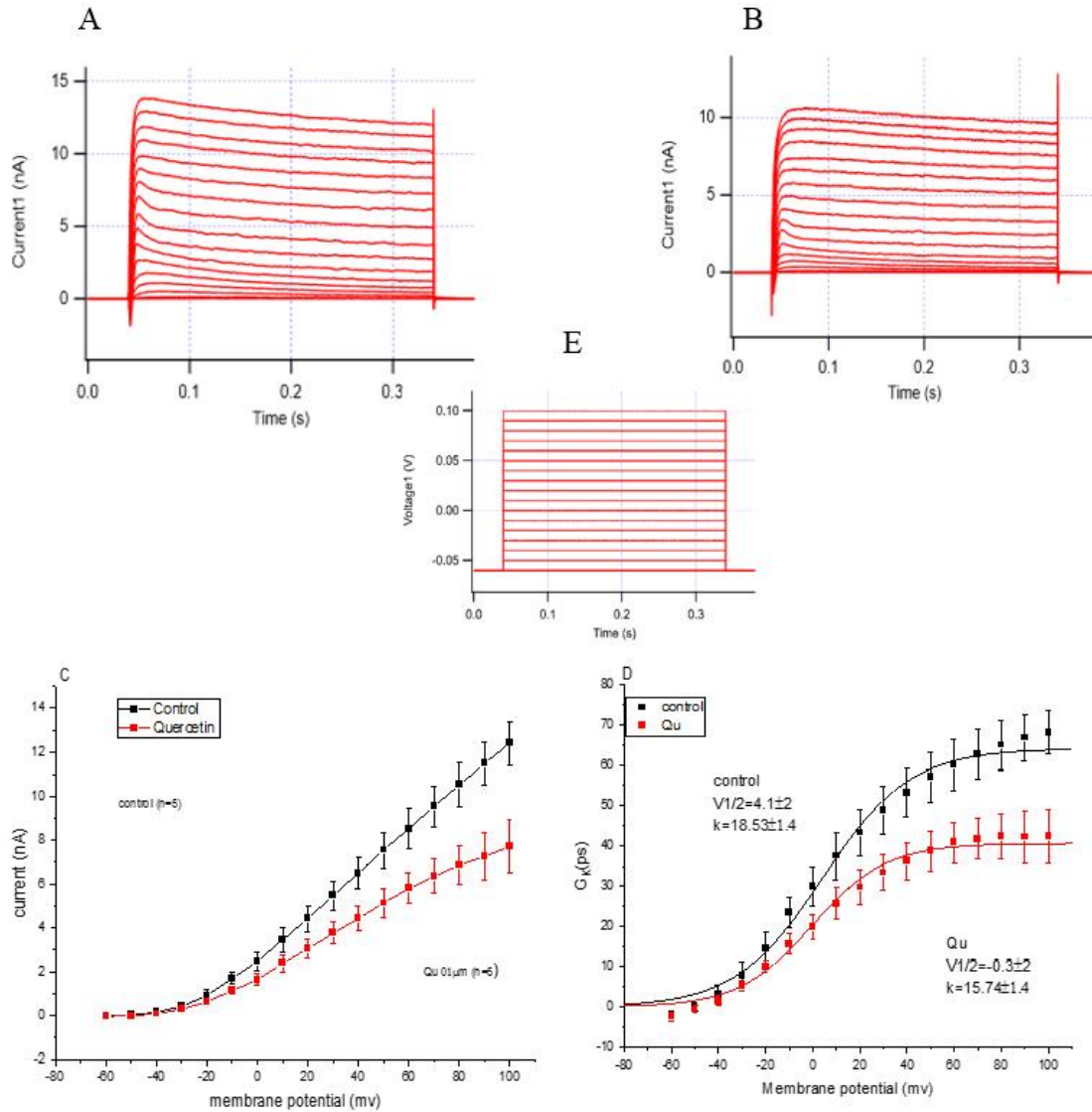

Figure 4.4. K^+ current in DRG neurons and their modulation by quercetin 1 μ M. (A) I_K evoked in neurons in response to voltage step protocol; (B) I_K after adding 1 μ M quercetin; (C) I-V curve; (D) conductance (G_K) curve; (E) steps of the potential to elicit the current. The cells were subjected to changes in the potential ranging from -60 mV to +80 mV in 10 mV increments to cause the currents shown. ($V_{1/2} = 4.1 \pm 2$ and 0.3 ± 2 ; $K = 18.35 \pm 1.4$ and 15.74 ± 1.4 for control and quercetin 1 μ M respectively; $n = 5$ for control and quercetin). There is no significant change in the $V_{1/2}$.

4.2.2. Quercetin 10 μM

Quercetin 10 μM decreased the maximal conductance by 37.8% and also the peak current was decreased, $V_{1/2}$ doesn't change before and after adding quercetin.

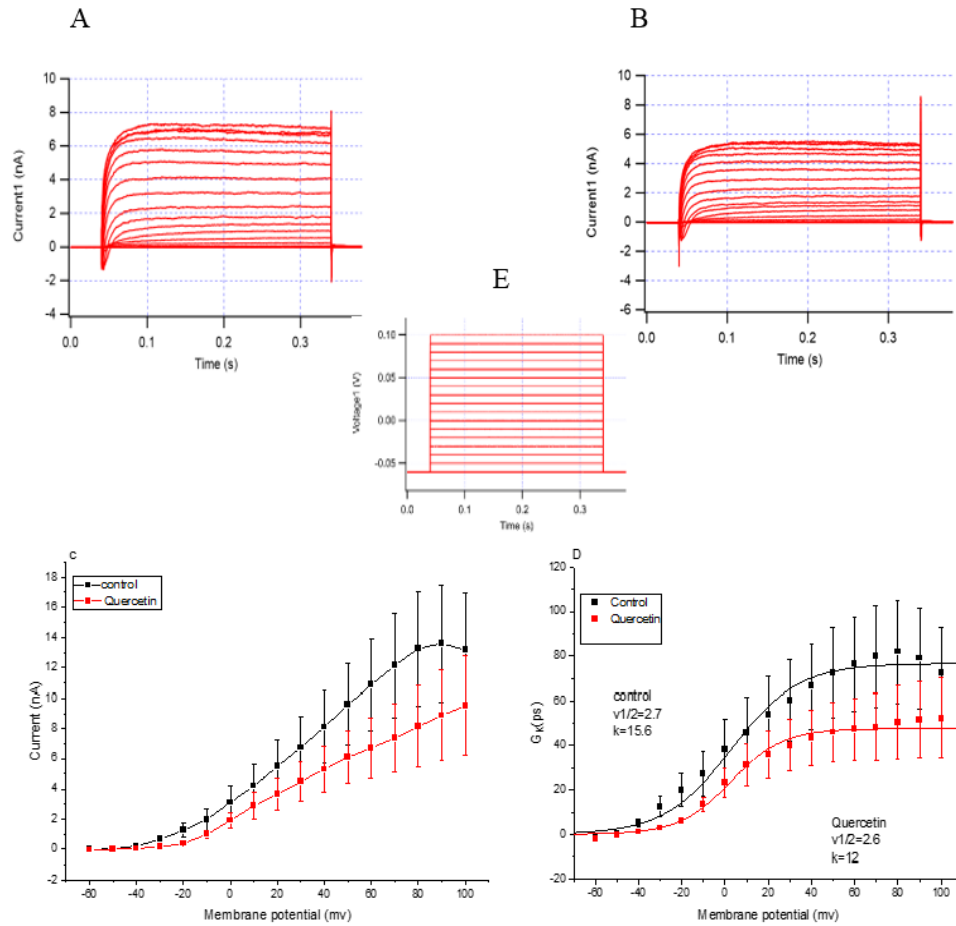

Figure 4.5. K^+ current in DRG neurons and their modulation by quercetin 10 μM . (A) I_K evoked in neurons in response to voltage step protocol; (B) I_K after adding 10 μM quercetin; (C) I-V curve; (D) conductance (G_K) curve; (E) steps of the potential to elicit the current. The cells were subjected to changes in the potential ranging from -60 mV to +80 mV in 10 mV increments to cause the currents shown. ($V_{1/2} = 2.7$ and 2.6; $k = 15.6$ and 12 for control and quercetin 10 μM respectively; $n = 5$ for control and quercetin). There is no significant change in $V_{1/2}$.

4.2.3. Quercetin 100 μM

Effect of quercetin 100 μM on the K^+ current, the results showed that quercetin 100 μM decreased the maximal conductance by 84% and the peak current decreased.

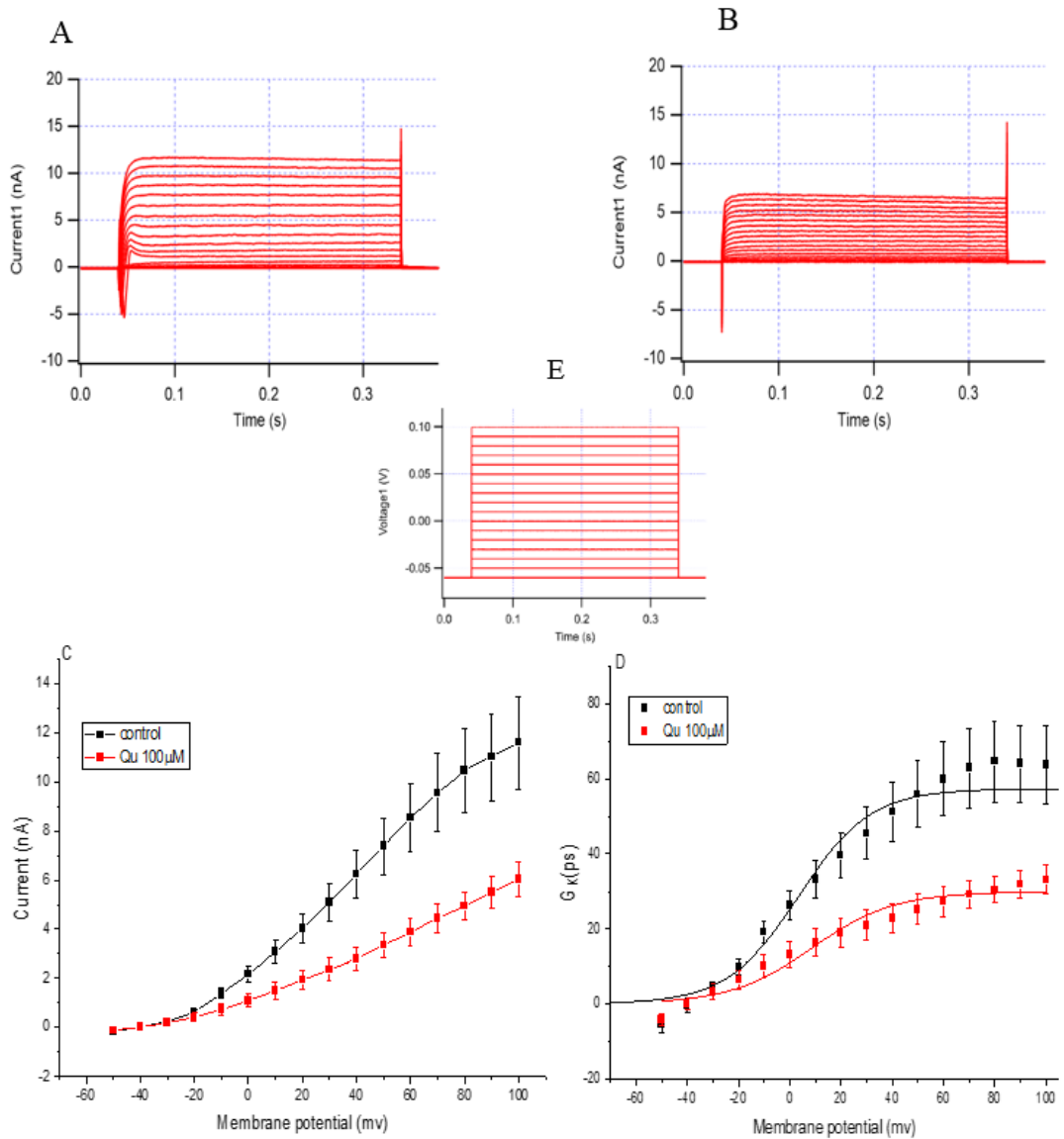

Figure 4.6. K^+ current in DRG neurons and their modulation by quercetin 100 μM . (A) I_K evoked in neurons in response to voltage step protocol; (B) I_K after adding 100 μM quercetin; (C) I-V curve; (D) conductance (G_K) curve; (E) steps of the potential to elicit the current. The cells were subjected to changes in the potential ranging from -60 mV to +80 mV in 10 mV increments to cause the currents shown. ($V_{1/2}=3.41185 \pm 2.92836$ and 8.78583 ± 5.67452 ; $K=14.08839 \pm 1.49431$ and 16.05136 ± 3.67359 for control and quercetin 100 μM respectively; $n=8$ for each). $V_{1/2}$ insignificantly changed ($p>0.05$).

4.3. Effect of RA on K⁺ peak current

4.3.1. RA 1 μM

RA 1 μM was found to decrease the maximal conductance by 12.3%, there is no significant changes in $V_{1/2}$ value.

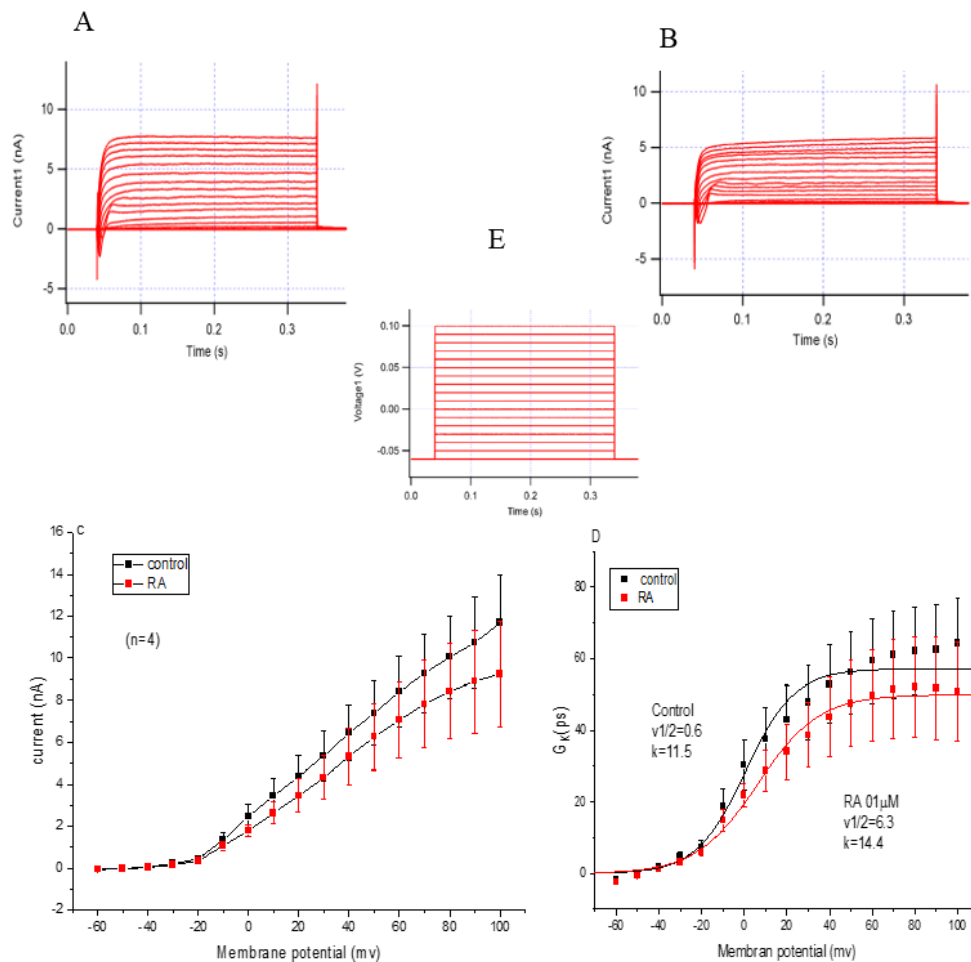

Figure 4.7. K⁺ current in DRG neurons and their modulation by RA 1 μM. (A) I_K evoked in neurons in response to voltage step protocol; (B) I_K after adding 1 μM of RA; (C) I-V curve; (D) conductance (G_K) curve; (E) steps of the potential to elicit the current. The cells were subjected to changes in the potential ranging from -60 mV to +80 mV in 10 mV increments to cause the currents shown. ($V_{1/2}$ =0.6 and 6.3; K =11.5 and 14.4 for control and quercetin 100 μM respectively; n=4 for each).

4.3.2. RA 10 μM

RA 10 μM decreased the maximal conductance by 21.2%, there is no significant effect on $V_{1/2}$.

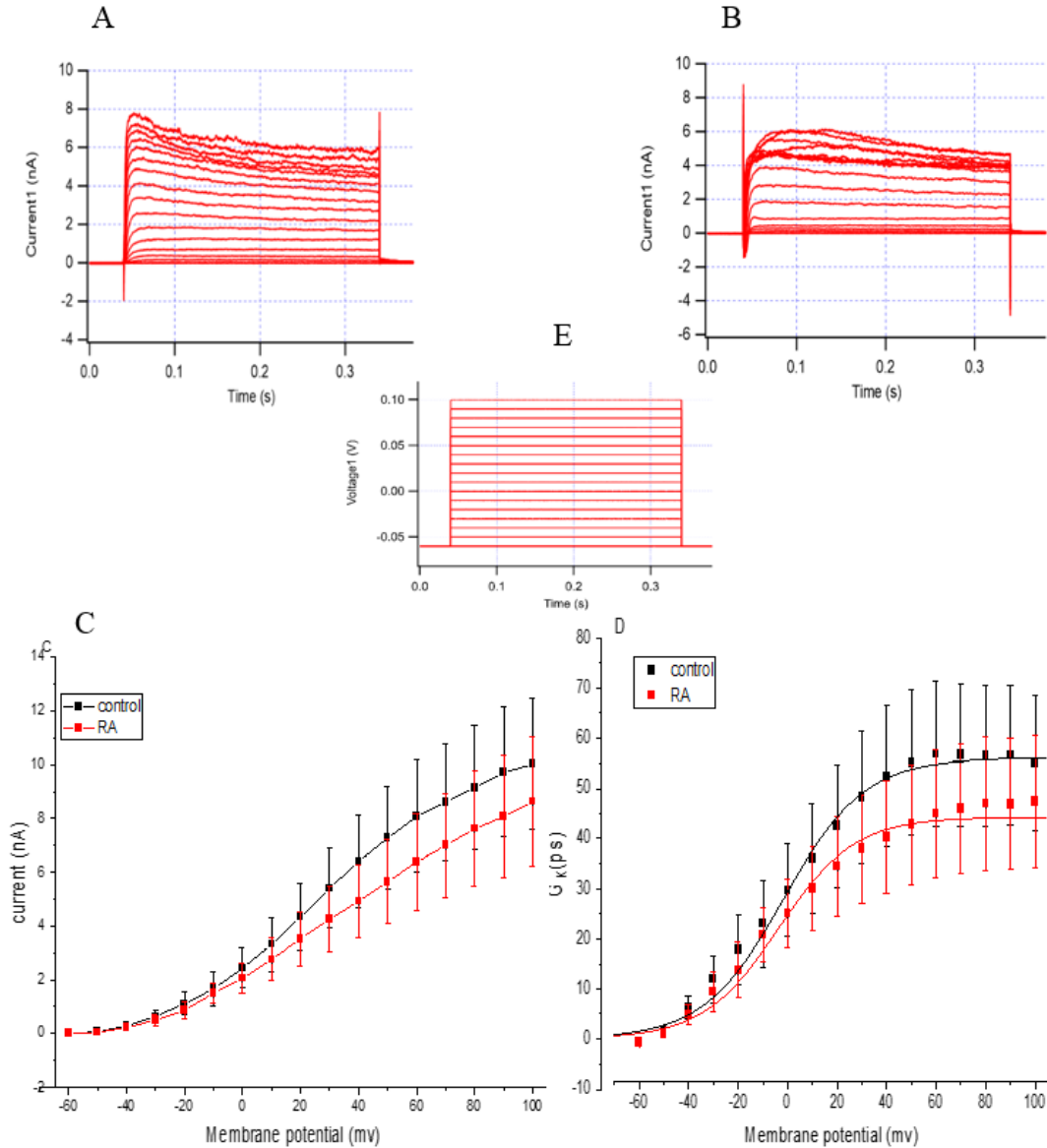

Figure 4.8. K^+ current in DRG neurons and their modulation by RA 10 μM . (A) IK evoked in neurons in response to voltage step protocol; (B) IK after adding 10 μM of RA; (C) I-V curve; (D) conductance (GK) curve; (E) steps of the potential to elicit the current. The cells were subjected to changes in the potential ranging from -60 mV to +80 mV in 10 mV increments to cause the currents shown. ($V_{1/2} = -1.59211 \pm 6.89794$ and -3.64586 ± 5.58985 ; $K = 16.23333 \pm 2.10538$ and 15.32949 ± 1.82299 ; for control and RA 10 respectively; $n=4$ for each).

4.3.3. RA 100 μM

The effect of RA 100 μM on the K^+ current showed to decrease the peak current and decrease the maximal conductance by 31.2%, there is no significant changes in $V_{1/2}$.

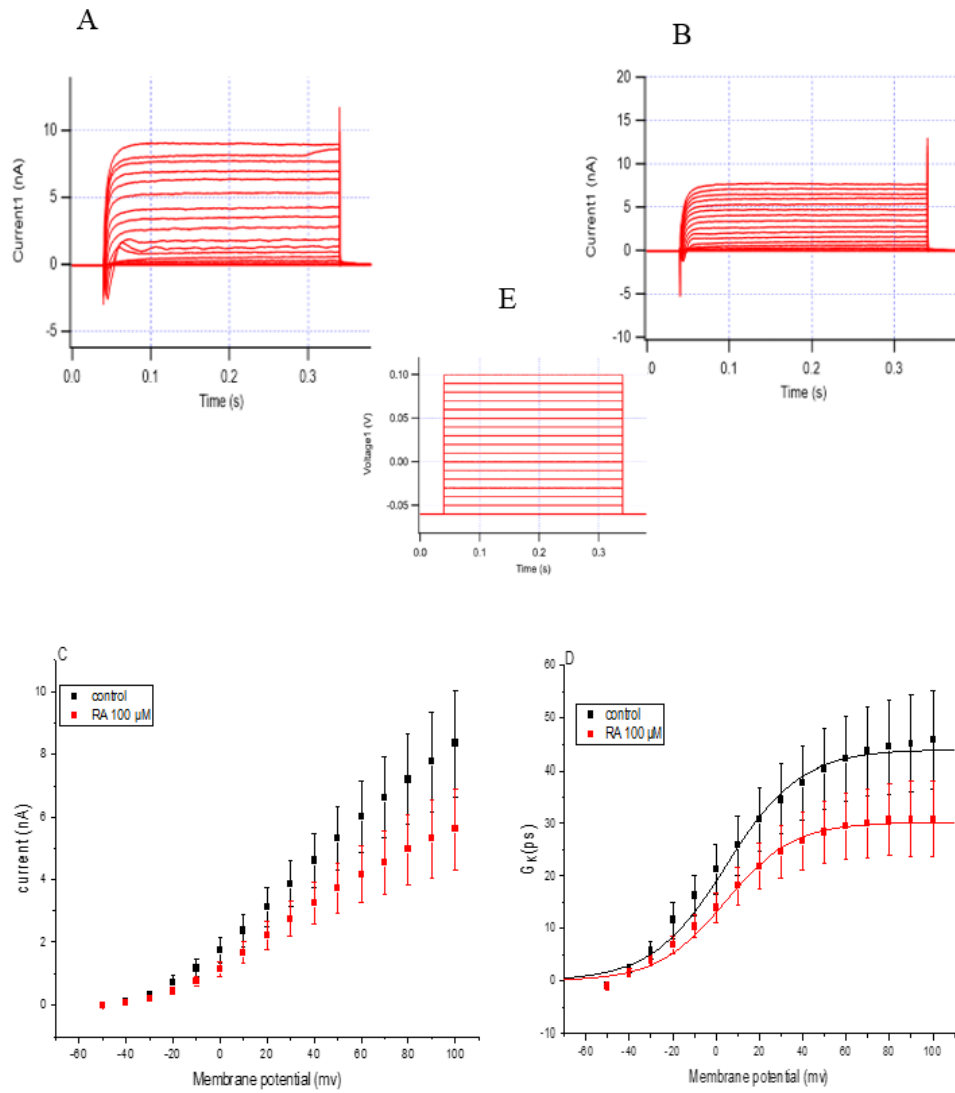

Figure 4.9. K^+ current in DRG neurons and their modulation by RA 100 μM . (A) I_K evoked in neurons in response to voltage step protocol; (B) I_K after adding 100 μM of RA; (C) I-V curve; (D) conductance (G_K) curve; (E) steps of the potential to elicit the current. The cells were subjected to changes the potential ranging from -60 mV to +80 mV in 10 mV increments to cause the currents shown. ($V_{1/2}$ = 4.65831 ± 2.78442 and 4.27284 ± 2.76499 ; K = 17.14918 ± 1.16552 and 15.66187 ± 1.30394 ; for control and RA 100 respectively $n=9$ for each).

4.4. Concentration dependent effect

The three figures represent the relation between the different concentrations of the drugs and the response they produced on the peak K^+ current, they don't affect K^+ current in a concentration dependent manner.

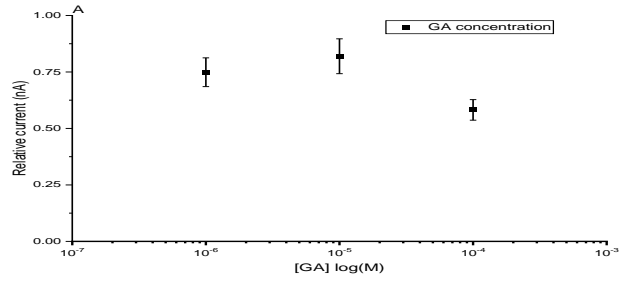

Figure 4.10. Concentration dependent effect of GA

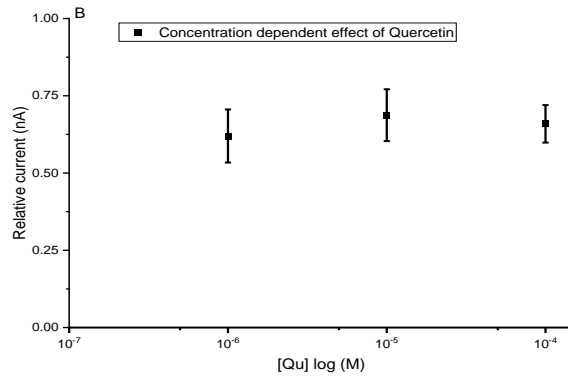

Figure 4.11. Concentration dependent effect of RA

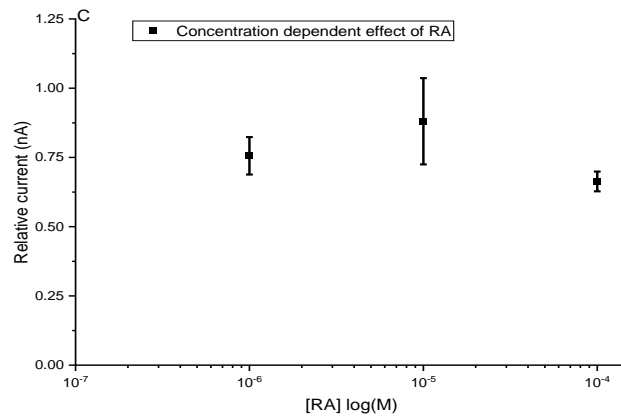

Figure 4.12. Concentration dependent effect of quercetin

4.5. Effect of pharmacological agents on the AP parameters

4.5.1. GA effect

The figure below shows the evoked AP before and after adding 1 μM GA, we can notice the decrease of the amplitude after adding GA and increase the duration (Figure 4.13 (B)).

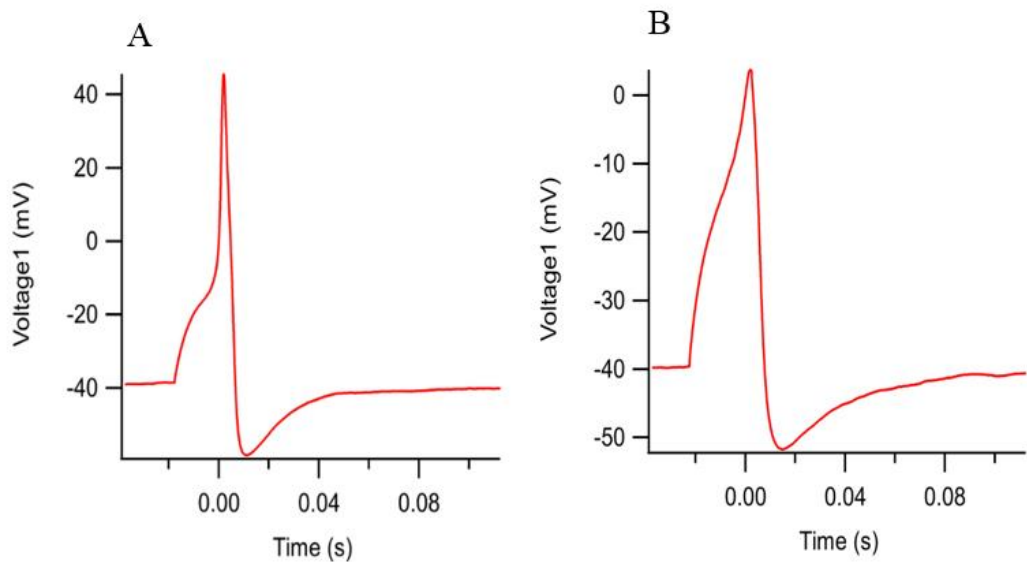

Figure 4.13. GA decrease AP amplitude and increase duration for evoked AP by injection a current; (A) AP for control; (B) AP after adding GA. Results was expressed as mean \pm S.E.M; For 10 and 10 μM the results were statistically insignificant ($p > 0.05$). for GA 100 μM there was significant differences for threshold, duration and AHP ($p < 0.05$); $n = 4$.

Table 4.1. *The table AP parameters before applying the chemicals.*

Control	Concentration	Cell 01	Cell 02	Cell 03	Cell 04
Threshold (mv)	1 μ M	-38.174439	-10.263061	-49.206544	-58.291625
	10 μ M	-43.011475	-56.845091	-35.363771	-50.759889
	100 μ M	-52.148439	-61.309814	-58.831789	-45.425415
Peak (mV)	1 μ M	45.562744	47.51892	46.023559	30.5084229
	10 μ M	33.358764	47.644041	33.541869	32.339476
	100 μ M	34.420777	24.865722	32.662965	21.585083
AP	1 μ M	21.448227	4.9220445	22.909235	14.639777
Duration (ms) (90%)	10 μ M	23.262348	18.587802	13.289727	23.982653
	100 μ M	24.981149	24.953036	15.94525	20.347465
AHP (mV)	1 μ M	-58.209229	-62.603757	-61.358642	-69.351196
	10 μ M	-57.565309	-66.082761	-41.571043	-64.508058
	100 μ M	-67.59949	-68.328857	-64.691164	-58.99353

Table 4.2. *The table showing the effect of three doses of GA 1, 10 and 100 μ M on AP parameters.*

GA	Concentration	Cell 01	Cell 02	Cell 03	Cell 04	P value
Threshold (mv)	1 μ M	-39.581299	-8.7341312	-46.365358	-44.940185	0.294
	10 μ M	-40.240478	-48.236083	-39.096069	-45.782469	0.3104
	100 μ M	-47.546387	-58.496095	-57.4646	-43.569945	0.0337
Peak (mV)	1 μ M	30.7445067	40.31067	47.625732	27.835082	0.1985
	10 μ M	32.012939	39.208986	37.432861	21.502685	0.3018
	100 μ M	34.61609	31.118775	31.765748	14.190674	0.7080
AP Duration (ms) (90%)	1 μ M	28.546166	4.8880451	21.188805	16.028063	0.4439
	10 μ M	22.171432	16.662858	19.567618	20.954462	0.9796
	100 μ M	25.799271	27.184254	19.753185	23.55694	0.0308
AHP (mV)	1 μ M	-51.574707	-58.807373	-59.866332	-57.476807	0.0764
	10 μ M	-53.814698	-51.428221	-45.224	-55.642702	0.2261
	100 μ M	-64.071655	-66.058353	-62.889528	-55.85327	0.0065

4.5.2. Quercetin effect

Figure 4.14 illustrate the effect of quercetin on the parameter of AP. Concentration 1 μM affect the threshold and AP duration significantly as it is shown in (Table 4.2.)

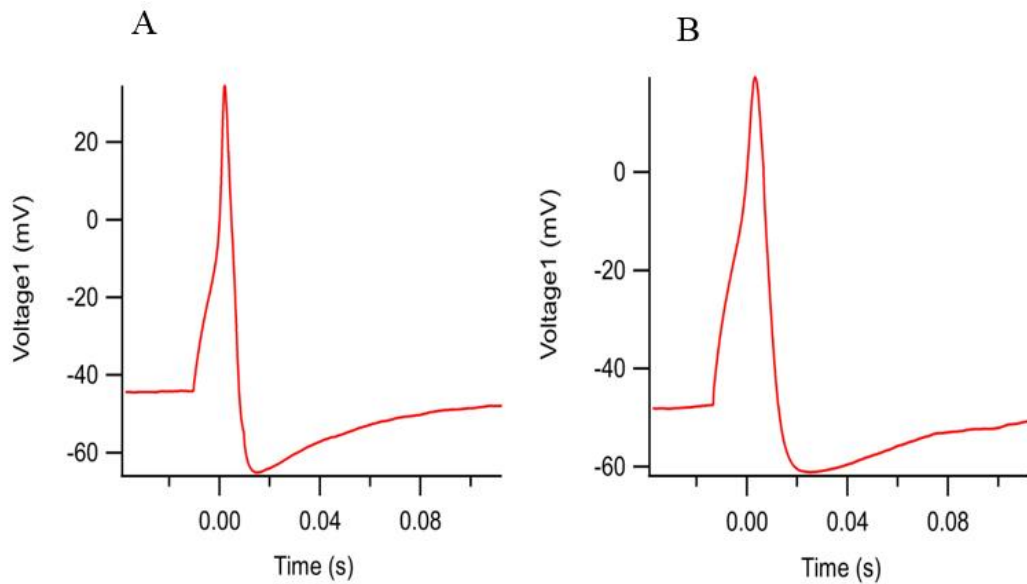

Figure 4.14. Quercetin decreases the amplitude, increases the duration of AP; (A) AP for control; (B) evoked AP after adding quercetin. The results calculated on the base of mean \pm S.E.M.; Quercetin 1 μM affect the threshold and duration significantly ($p < 0.05$), the other concentration 10 and 100 μM produced statistically insignificant results ($p > 0.05$), $n = 3$ for 10, 100 μM and $n = 5$ for 1 μM .

Table 4.3. *The table showing AP parameters before applying the chemical.*

Control	Concentration	Cell 01	Cell 02	Cell 03	Cell 04	Cell 05
Threshold (mv)	1 μ M	-43.887328	-32.336425	--64.248659		
	10 μ M	-43.475341	-53.137206	-43.844603	-47.451783	-45.53650
	100 μ M	-41.897584	-55.523682	-34.741212		
Peak (mV)	1 μ M	34.597777	4.3823244	24.499511		
	10 μ M	55.093385	23.03772	27.621459	37.277222	35.33021
	100 μ M	6.3690185	21.725465	47.247313		
AP Duration (ms) (90%)	1 μ M	19.085265	20.76851	19.41912		
	10 μ M	15.891206	19.572632	26.307676	21.937724	20.31839
	100 μ M	18.787457	25.100607	13.513342		
AHP (mV)	1 μ M	-64.868167	-50.643921	-73.086545		
	10 μ M	-60.699463	-66.744998	-60.043335	-57.501219	-61.81641
	100 μ M	-61.340332	-65.423585	-54.418944		

Table 4.4. *The table showing the effect of three doses of quercetin 1, 10 and 100 μ M on AP parameters.*

Quercetin	Concentration	Cell 01	Cell 02	Cell 03	Cell 04	Cell 05	P value
Threshold (mv)	1 μ M	-40.399901	-26.525879	-61.27624			0.0037
	10 μ M	-41.394044	-45.74585	-33.96606	-45.15259	-42.11121	0.1071
	100 μ M	-22.994276	-36.12134	-44.89824			0.4382
Peak (mV)	1 μ M	19.354248	11.618042	36.578368			0.8735
	10 μ M	26.922608	6.5856935	38.983155	40.728759	31.838991	0.4441
	100 μ M	28.836126	14.345683	37.165322			0.8876
AP Duration (ms) (90%)	1 μ M	23.670288	21.995971	22.664463			0.0425
	10 μ M	19.205665	27.59725	42.310324	24.154086	20.437518	0.1329
	100 μ M	20.54845	27.37113	14.653521			0.3895
AHP (mV)	1 μ M	-60.180664	-41.009523	-70.01952			0.1093
	10 μ M	-52.55127	-45.858763	-47.16796	-59.44214	-58.27942	0.0921
	100 μ M	-21.21421	-25.18587	-48.67554			0.1296

4.5.3. RA effect

The figure below illustrates the elicited AP before and after adding RA, as it is presented in the Table 4.2. the concentration 1 μM of RA significantly increased the threshold, duration and decreased the peak.

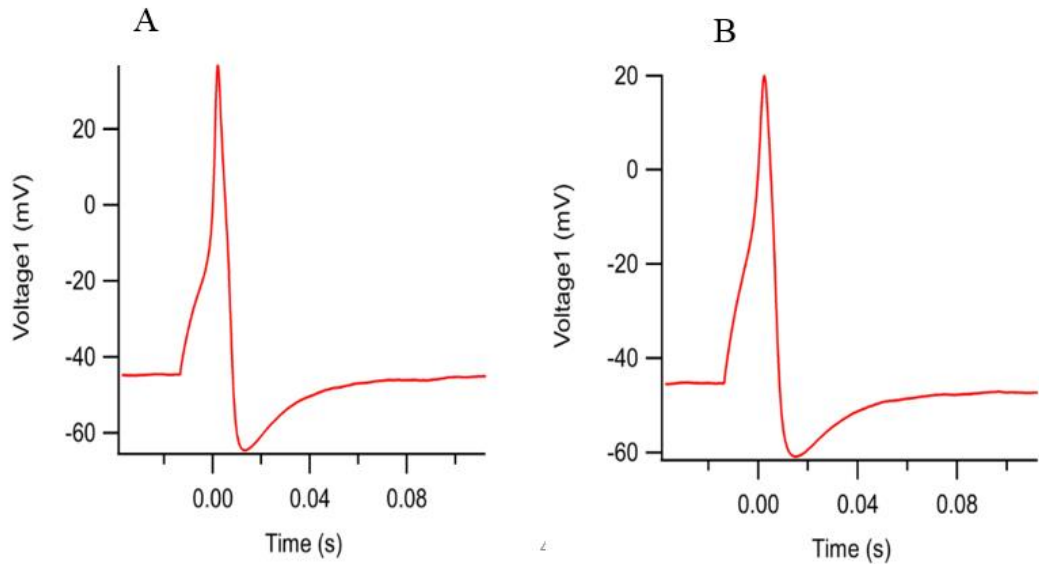

Figure 4.15. Changing of AP parameters after adding RA. (A) elicited AP for control cell; (B) elicited AP after adding RA, the results introduced as mean \pm S.E.M, 1 μM of RA significantly affected AP parameters (threshold, peak and duration) ($p < 0.05$). The other two concentration 10 and 100 produced statistically insignificant results ($p > 0.05$), except 10 μM significantly affect AHP ($p < 0.05$), $n = 4$.

Table 4.5. *The table showing AP parameters before applying the chemical*

Control	Concentr ation	Cell 01	Cell 02	Cell 03	Cell 04
Threshold (mv)	1 μ M	-47.20569	-39.707519	-50.830077	-48.4503172
	10 μ M	-4.0344237	-48.76709	-17.221069	
	100 μ M	-54.699708	-42.037964	-45.544434	-46.075441
Peak (mV)	1 μ M	36.798097	42.98706	37.440065	40.950316
	10 μ M	43.170165	32.260131	23.278808	
	100 μ M	21.972656	31.048585	15.805054	28.564453
AP Duration (ms) (90%)	1 μ M	18.990163	17.169589	20.173953	19.1446127
	10 μ M	4.8243315	31.186063	5.6328387	
	100 μ M	26.115235	10.585717	11.355154	20.897828
AHP (mV)	1 μ M	-64.520262	-68.322755	-61.947633	-62.850952
	10 μ M	-63.970946	-61.071776	-61.624147	
	100 μ M	-65.71655	-60.470581	-57.482909	-60.012817

Table 4.6. *The table showing the effect of three doses of RA 1, 10 and 100 μ M on AP parameters*

RA	Concentr ation	Cell 01	Cell 02	Cell 03	Cell 04	P value
Threshold (mv)	1 μ M	-43.33899	-37.9071047	-43.020628	-40.098266	0.0406
	10 μ M	-5.4656984	-45.986939	-16.543578		0.6343
	100 μ M	-50.845336	-39.212037	-46.575926	-46.655275	0.3748
Peak (mV)	1 μ M	30.918824	31.162597	30.161498	83.413332	0.0374
	10 μ M	43.362428	45.312501	26.51062		0.2926
	100 μ M	16.159058	32.702636	3.7963868	33.682249	0.5233
AP Duration (ms) (90%)	1 μ M	20.007582	21.984745	22.303023	23.7660554	0.4439
	10 μ M	6.6767409	28.255045	7.0511475		0.9796
	100 μ M	27.000112	11.858558	17.915031	22.356458	0.0308
AHP (mV)	1 μ M	-60.592651	-61.422728	-64.410403	-60.354613	0.2589
	10 μ M	-56.182861	-57.110596	-55.078126		0.0325
	100 μ M	-58.953859	-60.7666	-51.937867	-58.578491	0.1374

5. DISCUSSION

In view of the data presented in this study, the effect of some polyphenols has been evaluated to show their effect on the electrophysical properties of DRG cells, the current passing through the biological membrane of the cell depends mainly on open probability and duration, number of channels and single channel current amplitude.

In recent years there has been increasing evidence that polyphenols play a crucial role in peripheral nociception and thus in the development of chronic pain syndromes. Several studies in the literature used diabetic and alcoholic neuropathic models to demonstrate the effect of those polyphenols by mechanical and thermal methods. The neuroprotective mechanism appears to be due to the prevention of damage caused by oxidative stress in the neurons of the dorsal horn of the spinal cord, such as lipid peroxidation and protein nitrosylation. Since these polyphenols decrease nitric oxide synthase expression, probably the protective mechanism would involve decreasing NO production and peroxynitrite generation and, consequently, oxidative stress [23, 40, 65, 152]. The DRG cells are important for the generation of impulses at peripheral nociceptive endings, but they are also able to pass on already generated APs in C-fibers [153], that's why we chose DRG cells to analyze the analgesic effect of examined polyphenols and evaluate their effect on the K^+ current.

Chronic pain is usually associated with excessive somatosensory system excitability and is undertreated in clinics. Throughout the nervous system, K^+ channels are critical determinants of neuronal function. Opening these channels allows for a hyperpolarizing K^+ efflux through the plasma membrane, which reduces neuronal excitability by counteracting inward ion conductance. In humans, K^+ channels are the most common, widely distributed, and diverse class of ion channels, governed by 78 genes [105].

An AP is understood to be the rapid depolarization from the resting potential to positive potentials, which automatically repolarize to the resting potential with the time course typical for the cell type. The AP has a positive peak value of about +60 mV, the duration for this is approximately 1 ms for the nerve. In the spread phase, the rapid positive change in potential begins due to increased Na^+ conductivity. As a result, the membrane potential briefly approaches the Na^+ equilibrium potential. During depolarization, the K^+ conductivity increases with a delay, which initiates the repolarization with the K^+ outflow. After an AP, the membrane appears to be non-

excitable for about 2 ms. In this absolute refractory phase, the Na⁺ channel system is still inactivated. During the following phase, the cell is relatively refractory; only strong depolarizations can trigger potentials of reduced amplitude [143].

K⁺ channels promote a considerably rapid transmembrane K⁺ efflux upon activation, which can affect AP threshold, frequency, and waveform. Because the opening of K⁺ hyperpolarizes or repolarizes the neuronal membrane, this role can restrict AP generation and firing rate. Depending on the biophysical profile and specific subcellular localization in sensory neurons, conduction of K⁺ channel is thought to suppress peripheral excitability by counteracting AP initiation at peripheral nerve terminals, limiting neurotransmitter release at central terminals or lowering conduction fidelity across the axon. Furthermore, while normal sensory transduction does not rely on cell soma spiking, K⁺ channels may act as a brake on spontaneous activity developing in the DRG soma or other ectopic loci in chronic pain states. Indeed, peripheral K⁺ channel openers on the cell body or terminals always reduce DRG excitability, while K⁺ channel blockers always increase firing [105, 154, 155]. Opening K⁺ channels in the CNS could theoretically lead to increased nociception, especially if the affected neuron is part of an inhibitory circuit. Nonetheless, the available evidence suggests that a variety of antinociceptive drugs work by directly opening K⁺ channels in the spinal cord.

GA reduced maximal conductance by 84.1, 13.7 and 43.6% for the concentrations 1, 10 and 100 μM respectively. From the results we found that current and conductance was shifted by GA to depolarized side. The effect of GA on AP parameters also have been evaluate where 100 μM GA increased the threshold potential and AHP potential and increased AP duration.

The quercetin effect on the maximal conductance was 36.3, 37.8 and 84% of the concentrations 1, 10 and 100 μM consecutively, and I-V and G_k curves shifted to depolarized direction. The effect on the AP just concentration 1 μM was statistically significant and increased threshold potential and duration of AP 90%.

RA decreased the maximal conductance by 12.3, 21.2 and 31.2% of the concentrations 1, 10 and 100 μM respectively, the effect of concentration 1 μM on AP parameters increased the threshold potential and duration of AP 90% and decreased the peak, other parameters weren't statistically significant. 10 μM just decreased AHP potential.

According to the data presented in this study, we concluded that GA, quercetin, and RA could prevent the development of pain by their effect by suppression K^+ current that participate in the pain initiation, and also, they increased the threshold and duration of AP in acutely dissociated DRG cells of rats. So, to produce the pain need higher stimulus for AP to elicited from this view, the examined substances have the potential to be promising agent as a pain reliever.

6. CONCLUSION

In view of the data presented in our study, we concluded that GA, quercetin and have a potential effect of suppression of K^+ current and conductance to a degree higher than RA so they could have the probability to act as analgesic according to results of all parameters that have been evaluated, but that need further investigation. The effect doesn't depend on the concentration because for all three substances; the effect of concentration 100 μ M is less than the effect of other doses either the higher dose decreases the number of channels to be activated or time open probability of the channel.

The data presented here can lead to a better understanding of the effect of these polyphenols on the DRG and need more investigation and studies on the exact effect and type of channels they are working on.

REFERENCES

- [1] Kühnau, J. (1976). The Flavonoids . A Class of Semi-Essential Food Components : Their Role in Human Nutrition. *World Rev. Nutr. Diet.*, 24 (2), 117–191.
- [2] Vargas, A.J., Burd, R. (2010). Hormesis and synergy : pathways and mechanisms of quercetin in cancer prevention and management. *Nutr. Rev.*, 68 (7), 418–428.
- [3] Jain, P.K., and , M. D. Kharya, A. Gajbhiye, U. V. S. Sara, V.K.S. (2010). Flavonoids as nutraceuticals. A review. *Herba Pol.*, 56 (2), 213–238.
- [4] Pandey, K.B., and Rizvi, S.I. (2009). Plant Polyphenols as Dietary Antioxidants in Human Health and Disease. *Oxid. Med. Cell. Longev.*, 2 (5), 270–278.
- [5] Rivera, L., Morón, R., Sánchez, M., Zarzuelo, A., & Galisteo, M. (2008). Quercetin ameliorates metabolic syndrome and improves the inflammatory status in obese Zucker rats. *Obesity*, 16 (9), 2081–2087.
- [6] Scalbert, A., Johnson, I.T., and Saltmarsh, M. (2005). Polyphenols: antioxidants and beyond. *Am. J. Clin. Nutr.*, 81 (1), 215–217.
- [7] Petersen, M., and Simmonds, M.S.J. (2003). Rosmarinic acid. *Phytochemistry*, 62 (2), 121–125.
- [8] Anwar, S., Shamsi, A., Shahbaaz, M., Queen, A., Khan, P., Hasan, G.M., Islam, A., Alajmi, M.F., Hussain, A., Ahmad, F., and Hassan, M.I. (2020). Rosmarinic Acid Exhibits Anticancer Effects via MARK4 Inhibition. *Sci. Rep.*, 10 (1), 1–13.
- [9] Swamy, M.K., Sinniah, U.R., and Ghasemzadeh, A. (2018). Anticancer potential of rosmarinic acid and its improved production through biotechnological interventions and functional genomics. *Appl. Microbiol. Biotechnol.*, 102 (18), 7775–7793.
- [10] Fialová, S.B., Kello, M., Čoma, M., Slobodníková, L., Drobná, E., Holková, I., Garajová, M., Mrva, M., Zachar, V., and Lukáč, M. (2019). Derivatization of rosmarinic acid enhances its in vitro antitumor, antimicrobial and antiprotozoal properties. *Molecules*, 24 (6), 1078.
- [11] Colica, C., Di Renzo, L., Aiello, V., De Lorenzo, A., and Abenavoli, L. (2018). Rosmarinic Acid as Potential Anti-Inflammatory Agent. *Rev. Recent Clin. Trials*, 13 (4), 240–242.
- [12] Qiao, S., Li, W., Tsubouchi, R., Haneda, M., Murakami, K., Takeuchi, F., Nisimoto, Y., and Yoshino, M. (2005). Rosmarinic acid inhibits the formation of

- reactive oxygen and nitrogen species in RAW264.7 macrophages. *Free Radic. Res.*, 39 (9), 995–1003.
- [13] Gao, L.P., Wei, H.L., Zhao, H.S., Xiao, S.Y., and Zheng, R.L. (2005). Antiapoptotic and antioxidant effects of rosmarinic acid in astrocytes. *Pharmazie*, 60 (1), 62–65.
- [14] Shimojo, Y., Kosaka, K., Noda, Y., Shimizu, T., and Shirasawa, T. (2010). Effect of rosmarinic acid in motor dysfunction and life span in a mouse model of familial amyotrophic lateral sclerosis. *J. Neurosci. Res.*, 88 (4), 896–904.
- [15] Alkam, T., Nitta, A., Mizoguchi, H., Itoh, A., and Nabeshima, T. (2007). A natural scavenger of peroxynitrites, rosmarinic acid, protects against impairment of memory induced by A β 25-35. *Behav. Brain Res.*, 180 (2), 139–145.
- [16] Li, M., Cui, M.M., Kenechukwu, N., Gu, Y.W., Chen, Y.L., Zhong, S.J., Gao, Y.T., Cao, X.Y., Wang, L., Liu, F.M., and Wen, X.R. (2020). Rosmarinic acid ameliorates hypoxia/ischemia induced cognitive deficits and promotes remyelination. *Neural Regen. Res.*, 15 (5), 894–902.
- [17] Dastmalchi, K., Ollilainen, V., Lackman, P., Gennäs, G.B. af, Dorman, H.J.D., Järvinen, P.P., Yli-Kauhaluoma, J., and Hiltunen, R. (2009). Acetylcholinesterase inhibitory guided fractionation of *Melissa officinalis* L. *Bioorg. Med. Chem.*, 17 (2), 867–871.
- [18] Ren, P., Jiang, H., Li, R., Wang, J., Song, N., Xu, H.M., and Xie, J.X. (2009). Rosmarinic acid inhibits 6-OHDA-induced neurotoxicity by anti-oxidation in MES23.5 cells. *J. Mol. Neurosci.*, 39 (1), 220–225.
- [19] Zhao, Y., Wang, J., Balleve, O., Luo, H., and Zhang, W. (2012). Antihypertensive effects and mechanisms of chlorogenic acids. *Hypertens. Res.*, 35 (4), 370–374.
- [20] Li, Li, Jingwei Tian, and X.L. (2008). Regression of atherosclerosis by Rosmarinic acid via regulating lipid metabolism and anti-inflammatory actions. *J. Mol. Cell. Cardiol.*, 44 (4), 718–719.
- [21] Zhang, X., Zhu, J.X., Ma, Z.G., Wu, H.M., Xu, S.C., Song, P., Kong, C.Y., Yuan, Y.P., Deng, W., and Tang, Q.Z. (2019). Rosmarinic acid alleviates cardiomyocyte apoptosis via cardiac fibroblast in doxorubicin-induced cardiotoxicity. *Int. J. Biol. Sci.*, 15 (3), 556–567.
- [22] Kelm, M.A., Nair, M.G., Strasburg, G.M., and DeWitt, D.L. (2000). Antioxidant

- and cyclooxygenase inhibitory phenolic compounds from *Ocimum sanctum* Linn. *Phytomedicine*, 7 (1), 7–13.
- [23] Thingore, C., Kshirsagar, V., and Juvekar, A. (2021). Amelioration of oxidative stress and neuroinflammation in lipopolysaccharide-induced memory impairment using Rosmarinic acid in mice. *Metab. Brain Dis.*, 36 (2), 299–313.
- [24] Sadeghi, A., Bastin, A.R., Ghahremani, H., and Doustimotlagh, A.H. (2020). The effects of rosmarinic acid on oxidative stress parameters and inflammatory cytokines in lipopolysaccharide-induced peripheral blood mononuclear cells. *Mol. Biol. Rep.*, 47 (5), 3557–3566.
- [25] Chu, X., Ci, X., He, J., Jiang, L., Wei, M., Cao, Q., Guan, M., Xie, X., and Deng, X. (2012). Effects of a natural prolyl oligopeptidase inhibitor, rosmarinic acid, on lipopolysaccharide-induced acute lung injury in mice. *Molecules*, 17 (3), 3586–3598.
- [26] Costa, R.S., Carneiro, T.C.B., Cerqueira-Lima, A.T., Queiroz, N.V., Alcântara-Neves, N.M., Pontes-De-Carvalho, L.C., Velozo, E.D.S., Oliveira, E.J., and Figueiredo, C.A. (2012). *Ocimum gratissimum* Linn. and rosmarinic acid, attenuate eosinophilic airway inflammation in an experimental model of respiratory allergy to *Blomia tropicalis*. *Int. Immunopharmacol.*, 13 (1), 126–134.
- [27] Ma, Z., Lu, Y., Yang, F., Li, S., He, X., Gao, Y., Zhang, G., Ren, E., Wang, Y., and Kang, X. (2020). Rosmarinic acid exerts a neuroprotective effect on spinal cord injury by suppressing oxidative stress and inflammation via modulating the Nrf2/HO-1 and TLR4/NF- κ B pathways. *Toxicol. Appl. Pharmacol.*, 397, 1–48.
- [28] Gautam, R.K., Gupta, G., Sharma, S., Hatware, K., Patil, K., Sharma, K., Goyal, S., Chellappan, D.K., and Dua, K. (2019). Rosmarinic acid attenuates inflammation in experimentally induced arthritis in Wistar rats, using Freund's complete adjuvant. *Int. J. Rheum. Dis.*, 22 (7), 1247–1254.
- [29] Wei, Y., Chen, J., Hu, Y., Lu, W., Zhang, X., Wang, R., and Chu, K. (2018). Rosmarinic Acid Mitigates Lipopolysaccharide-Induced Neuroinflammatory Responses through the Inhibition of TLR4 and CD14 Expression and NF- κ B and NLRP3 Inflammasome Activation. *Inflammation*, 41 (2), 732–740.
- [30] Lee, J., Kim, Y.S., and Park, D. (2007). Rosmarinic acid induces melanogenesis through protein kinase A activation signaling. *Biochem. Pharmacol.*, 74 (7), 960–968.

- [31] Sánchez-Campillo, M., Gabaldon, J.A., Castillo, J., Benavente-García, O., Del Baño, M.J., Alcaraz, M., Vicente, V., Alvarez, N., and Lozano, J.A. (2009). Rosmarinic acid, a photo-protective agent against UV and other ionizing radiations. *Food Chem. Toxicol.*, 47 (2), 386–392.
- [32] El Alaoui, C., Chemin, J., Fechtali, T., and Lory, P. (2017). Modulation of T-type Ca²⁺ channels by Lavender and Rosemary extracts. *PLoS One*, 12 (10), 1–21.
- [33] Priscilla, D.H., and Prince, P.S.M. (2009). Cardioprotective effect of gallic acid on cardiac troponin-T, cardiac marker enzymes, lipid peroxidation products and antioxidants in experimentally induced myocardial infarction in Wistar rats. *Chem. Biol. Interact.*, 179 (2–3), 118–124.
- [34] Stanely Mainzen Prince, P., Priscilla, H., and Devika, P.T. (2009). Gallic acid prevents lysosomal damage in isoproterenol induced cardiotoxicity in Wistar rats. *Eur. J. Pharmacol.*, 615 (1–3), 139–143.
- [35] Urizzi, P., Monje, M.C., Souchard, J.P., Abella, A., Chalas, J., Lindenbaum, A., Vergnes, L., Labidalle, S., and Nepveu, F. (1999). Antioxidant activity of phenolic acids and esters present in red wine on human low-density lipoproteins. *J. Chim. Phys. Physico-Chimie Biol.*, 96 (1), 110–115.
- [36] Jadon, A., Bhadauria, M., and Shukla, S. (2007). Protective effect of Terminalia bellerica Roxb. and gallic acid against carbon tetrachloride induced damage in albino rats. *J. Ethnopharmacol.*, 109 (2), 214–218.
- [37] Fernandes, F.H.A., and Salgado, H.R.N. (2016). Gallic Acid: Review of the Methods of Determination and Quantification. *Crit. Rev. Anal. Chem.*, 46 (3), 257–265.
- [38] Punithavathi, V.R., Stanely Mainzen Prince, P., Kumar, M.R., and Selvakumari, C.J. (2011). Protective effects of gallic acid on hepatic lipid peroxide metabolism, glycoprotein components and lipids in streptozotocin-induced type II diabetic wistar rats. *J. Biochem. Mol. Toxicol.*, 25 (2), 68–76.
- [39] Sun, J., Li, Y.Z., Ding, Y.H., Wang, J., Geng, J., Yang, H., Ren, J., Tang, J.Y., and Gao, J. (2014). Neuroprotective effects of gallic acid against hypoxia/reoxygenation-induced mitochondrial dysfunctions in vitro and cerebral ischemia/reperfusion injury in vivo. *Brain Res.*, 1589, 126–139.
- [40] Dhingra, M.S., Dhingra, S., Kumria, R., Chadha, R., Singh, T., Kumar, A., and Karan, M. (2014). Effect of trimethylgallic acid esters against chronic stress-

- induced anxiety-like behavior and oxidative stress in mice. *Pharmacol. Reports*, 66 (4), 606–612.
- [41] Sarkaki, A., Farbood, Y., Gharib-Naseri, M.K., Badavi, M., Mansouri, M.T., Haghparast, A., and Mirshekar, M.A. (2015). Gallic acid improved behavior, brain electrophysiology, and inflammation in a rat model of traumatic brain injury. *Can. J. Physiol. Pharmacol.*, 93 (8), 687–694.
- [42] Trevisan, G., Rossato, M.F., Tonello, R., Hoffmeister, C., Klafke, J.Z., Rosa, F., Pinheiro, K. V., Pinheiro, F. V., Boligon, A.A., Athayde, M.L., and Ferreira, J. (2014). Gallic acid functions as a TRPA1 antagonist with relevant antinociceptive and antiedematogenic effects in mice. *Naunyn. Schmiedebergs. Arch. Pharmacol.*, 387 (7), 679–689.
- [43] Du, Y. ya, Zou, L., Wang, X. xiu, Dai, L. yao, Ling, X. nan, and Xu, Z. xin (2020). Inhibitory effect of gallic acid on voltage-gated Na⁺ channels in rat cardiomyocytes. *Clin. Exp. Pharmacol. Physiol.*, 47 (5), 771–779.
- [44] George, K., Thomas, N.S., and Malathi, R. (2019). Modulatory Effect of Selected Dietary Phytochemicals on Delayed Rectifier K⁺ Current in Human Prostate Cancer Cells. *J. Membr. Biol.*, 252 (2), 195–206.
- [45] Hertog, M.G.L., Feskens, E.J.M., Kromhout, D., Hertog, M.G.L., Hollman, P.C.H., Hertog, M.G.L., and Katan, M.B. (1993). Dietary antioxidant flavonoids and risk of coronary heart disease: the Zutphen Elderly Study. *Lancet*, 342 (8878), 1007–1011.
- [46] Ishisaka, A., Ichikawa, S., Sakakibara, H., Piskula, M.K., Nakamura, T., Kato, Y., Ito, M., Miyamoto, K.I., Tsuji, A., Kawai, Y., and Terao, J. (2011). Accumulation of orally administered quercetin in brain tissue and its antioxidative effects in rats. *Free Radic. Biol. Med.*, 51 (7), 1329–1336.
- [47] Molina, M.F., Sanchez-Reus, I., Iglesias, I., and Benedi, J. (2003). Quercetin, a flavonoid antioxidant, prevents and protects against ethanol-induced oxidative stress in mouse liver. *Biol. Pharm. Bull.*, 26 (10), 1398–1402.
- [48] Jang, M.H., Piao, X.L., Kim, J.M., Kwon, S.W., and Park, J.H. (2008). Protective Effect of Quercetin against ICV Colchicine-induced Cognitive Dysfunctions and Oxidative Damage in Rats. *Phyther. Res.*, 22 (4), 544–549.
- [49] Moon, S.K., Cho, G.O., Jung, S.Y., Gal, S.W., Kwon, T.K., Lee, Y.C., Madamanchi, N.R., and Kim, C.H. (2003). Quercetin exerts multiple inhibitory

- effects on vascular smooth muscle cells: Role of ERK1/2, cell-cycle regulation, and matrix metalloproteinase-9. *Biochem. Biophys. Res. Commun.*, 301 (4), 1069–1078.
- [50] Dajas, F. (2012). Life or death: Neuroprotective and anticancer effects of quercetin. *J. Ethnopharmacol.*, 143 (2), 383–396.
- [51] Yang, R., Li, L., Yuan, H., Liu, H., Gong, Y., Zou, L., Li, S., Wang, Z., Shi, L., Jia, T., Zhao, S., Wu, B., Yi, Z., Gao, Y., Li, G., Xu, H., Liu, S., Zhang, C., Li, G., and Liang, S. (2019). Quercetin relieved diabetic neuropathic pain by inhibiting upregulated P2X4 receptor in dorsal root ganglia. *J. Cell. Physiol.*, 234 (3), 2756–2764.
- [52] Wu, C.H., Wu, C.F., Huang, H.W., Jao, Y.C., and Yen, G.C. (2009). Naturally occurring flavonoids attenuate high glucose-induced expression of proinflammatory cytokines in human monocytic THP-1 cells. *Mol. Nutr. Food Res.*, 53 (8), 984–995.
- [53] Kaur, R., Singh, D., and Chopra, K. (2005). Participation of $\alpha 2$ receptors in the antinociceptive activity of quercetin. *J. Med. Food*, 8 (4), 529–532.
- [54] Bhutada, P., Mundhada, Y., Bansod, K., Ubgade, A., Quazi, M., Umathe, S., and Mundhada, D. (2010). Reversal by quercetin of corticotrophin releasing factor induced anxiety- and depression-like effect in mice. *Prog. Neuro-Psychopharmacology Biol. Psychiatry*, 34 (6), 955–960.
- [55] Samad, N., Saleem, A., Yasmin, F., and Shehzad, M.A. (2018). Quercetin protects against stress-induced anxiety- and depression- like behavior and improves memory in male mice. *Physiol. Res.*, 67 (5), 795–808.
- [56] Anjaneyulu, M., Chopra, K., and Kaur, I. (2003). Antidepressant Activity of Quercetin, A Bioflavonoid, in Streptozotocin-Induced Diabetic Mice. *J. Med. Food*, 6 (4), 391–395.
- [57] Karimipour, M., Rahbarghazi, R., Tayefi, H., Shimia, M., Ghanadian, M., Mahmoudi, J., and Bagheri, H.S. (2019). Quercetin promotes learning and memory performance concomitantly with neural stem/progenitor cell proliferation and neurogenesis in the adult rat dentate gyrus. *Int. J. Dev. Neurosci.*, 74 (1), 18–26.
- [58] Patil, C.S., Singh, V.P., Satyanarayan, P.S.V., Jain, N.K., Singh, A., and Kulkarni, S.K. (2003). Protective effect of flavonoids against aging- and

- lipopolysaccharide-induced cognitive impairment in mice. *Pharmacology*, 69 (2), 59–67.
- [59] Rivera, F., Urbanavicius, J., Gervaz, E., Morquio, A., and Dajas, F. (2004). Some aspects of the in vivo neuroprotective capacity of flavonoids: Bioavailability and structure-activity relationship. *Neurotox. Res.*, 6 (7), 543–553.
- [60] Cho, J.Y., Kim, I.S., Jang, Y.H., Kim, A.R., and Lee, S.R. (2006). Protective effect of quercetin, a natural flavonoid against neuronal damage after transient global cerebral ischemia. *Neurosci. Lett.*, 404 (3), 330–335.
- [61] Haleagrahara, N., Radhakrishnan, A., Lee, N., and Kumar, P. (2009). Flavonoid quercetin protects against swimming stress-induced changes in oxidative biomarkers in the hypothalamus of rats. *Eur. J. Pharmacol.*, 621 (1–3), 46–52.
- [62] Kawabata, K., Kawai, Y., and Terao, J. (2010). Suppressive effect of quercetin on acute stress-induced hypothalamic-pituitary-adrenal axis response in Wistar rats. *J. Nutr. Biochem.*, 21 (5), 374–380.
- [63] Picq, M., Cheav, S.L., and Prigent, A.F. (1991). Effect of two flavonoid compounds on central nervous system. Analgesic activity. *Life Sci.*, 49 (26), 1979–1988.
- [64] Wang, R., Qiu, Z., Wang, G., Hu, Q., Shi, N., Zhang, Z., Wu, Y., and Zhou, C. (2020). Quercetin attenuates diabetic neuropathic pain by inhibiting mTOR/p70S6K pathway-mediated changes of synaptic morphology and synaptic protein levels in spinal dorsal horn of db/db mice. *Eur. J. Pharmacol.*, 882, 173266.
- [65] Raygude, K.S., Kandhare, A.D., Ghosh, P., Ghule, A.E., and Bodhankar, S.L. (2012). Evaluation of ameliorative effect of quercetin in experimental model of alcoholic neuropathy in rats. *Inflammopharmacology*, 20 (6), 331–341.
- [66] Muto, N., Matsuoka, Y., Arakawa, K., Kurita, M., Omiya, H., Taniguchi, A., Kaku, R., and Morimatsu, H. (2018). Quercetin attenuates neuropathic pain in rats with spared nerve injury. *Acta Med. Okayama*, 72 (5), 457–465.
- [67] Callaghan, B.C., Cheng, H.T., Stables, C.L., Smith, A.L., and Feldman, E.L. (2012). Diabetic neuropathy: Clinical manifestations and current treatments. *Lancet Neurol.*, 11 (6), 521–534.
- [68] Public, G., and Priority, H. (2011). Pain as a Global Public Health Priority Pain as a Global Public Health Priority. *BMC. Public. Heal.*, 11 (1), 1–5.

- [69] Backonja, M.M., and Stacey, B. (2004). Neuropathic pain symptoms relative to overall pain rating. *J. Pain*, 5 (9), 491–497.
- [70] Dworkin, R.H., O'Connor, A.B., Backonja, M., Farrar, J.T., Finnerup, N.B., Jensen, T.S., Kalso, E.A., Loeser, J.D., Miaskowski, C., Nurmikko, T.J., Portenoy, R.K., Rice, A.S.C., Stacey, B.R., Treede, R.D., Turk, D.C., and Wallace, M.S. (2007). Pharmacologic management of neuropathic pain: Evidence-based recommendations. *Pain*, 132 (3), 237–251.
- [71] Sehgal, N., Colson, J., and Smith, H.S. (2013). Chronic pain treatment with opioid analgesics: Benefits versus harms of long-term therapy. *Expert Rev. Neurother.*, 13 (11), 1201–1220.
- [72] Mills, S.E.E., Nicolson, K.P., and Smith, B.H. (2019). Chronic pain: a review of its epidemiology and associated factors in population-based studies. *Br. J. Anaesth.*, 123 (2), e273–e283.
- [73] Cox, J.J., Reimann, F., Nicholas, A.K., Thornton, G., Roberts, E., Springell, K., Karbani, G., Jafri, H., Mannan, J., Raashid, Y., Al-gazali, L., Hamamy, H., Valente, E.M., Gorman, S., Williams, R., Mchale, D.P., Wood, J.N., Gribble, F.M., and Woods, C.G. (2006). An SCN9A channelopathy causes congenital inability to experience pain. *Nature*, 444 (7121), 894–898.
- [74] van Hecke, O., Torrance, N., and Smith, B.H. (2013). Chronic pain epidemiology – where do lifestyle factors fit in? *Br. J. Pain*, 7 (4), 209–217.
- [75] Dworkin, R.H., and Ph, D. (2002). An Overview of Neuropathic Pain : Syndromes , Symptoms , Signs , and Several Mechanisms Abstract : *Clin J Pain*, 18 (6), 343–349.
- [76] Torrance, N., Smith, B.H., Bennett, M.I., and Lee, A.J. (2006). The Epidemiology of Chronic Pain of Predominantly Neuropathic Origin. Results From a General Population Survey. *J. Pain*, 7 (4), 281–289.
- [77] Katherine E. Galluzzi, D. (2007). Managing Neuropathic Pain. *Am. Osteopath. Assoc.*, 107 (11), 39–48.
- [78] Kraychete, D.C., Gozzani, J.L., and Kraychete, A.C. (2008). Dor neuropática: aspectos neuroquímicos. *Rev. Bras. Anesthesiol.*, 58 (5), 492–505.
- [79] Benbouzid, M., Pallage, V., Rajalu, M., Waltisperger, E., Doridot, S., Poisbeau, P., Freund-Mercier, M.J., and Barrot, M. (2008). Sciatic nerve cuffing in mice: A model of sustained neuropathic pain. *Eur. J. Pain*, 12 (5), 591–599.

- [80] Bennett, G.J., and Model, T.H.E.N. (1993). An animal model of neuropathic pain: a review. *Off. J. Am. Assoc. Electrodiagn. Med.*, 16 (10), 1040-1048.
- [81] Peltier, A.C., and Russell, J.W. (2002). Recent advances in drug-induced neuropathies. *Curr. Opin. Neurol.*, 15 (5), 633–638.
- [82] Ruyang, T., Yang, Z., and Wei, F. (2015). Gabapentin prevents oxaliplatin-induced central sensitization in the dorsal horn neurons in rats. *Iran. J. Basic Med. Sci.*, 18 (5), 493–498.
- [83] Ling, B., Coudoré-Civiale, M.A., Balayssac, D., Eschalier, A., Coudoré, F., and Authier, N. (2007). Behavioral and immunohistological assessment of painful neuropathy induced by a single oxaliplatin injection in the rat. *Toxicology*, 234 (3), 176–184.
- [84] Garcia-Larrea, L., and Magnin, M. (2008). Pathophysiology of neuropathic pain: review of experimental models and proposed mechanisms. *Press. Medicale*, 37 (2 PART 2), 315–340.
- [85] Campbell, J.N., and Meyer, R.A. (2006). Mechanisms of Neuropathic Pain. *Neuron*, 52 (1), 77–92.
- [86] Kidd, B.L., and Urban, L.A. (2001). Mechanisms of inflammatory pain. *Br. J. Anaesth.*, 87 (1), 3–11.
- [87] Schaible, H.G., Von Banchet, G.S., Boettger, M.K., Bräuer, R., Gajda, M., Richter, F., Hensellek, S., Brenn, D., and Natura, G. (2010). The role of proinflammatory cytokines in the generation and maintenance of joint pain: Annals of the New York Academy of Sciences. *Ann. N. Y. Acad. Sci.*, 1193 (1), 60–69.
- [88] Ossipov, Michael H., Kozo Morimura, and F.P. (2015). Editorial, supportive care and psychological issues around cancer. *Curr. Opin. Support. Palliat. Care*, 8 (2), 38–39.
- [89] Basbaum, A.I., Bautista, D.M., Scherrer, G., and Julius, D. (2009). Cellular and Molecular Mechanisms of Pain Introduction: *Ann. N. Y. Acad. Sci.*, 139 (2), 267–284.
- [90] Apkarian, A.V., Bushnell, M.C., Treede, R.D., and Zubieta, J.K. (2005). Human brain mechanisms of pain perception and regulation in health and disease. *Eur. J. Pain*, 9 (4), 463–484.
- [91] Mense, S.S. (2004). Functional neuroanatomy for pain stimuli. Reception,

- transmission, and processing. *Schmerz*, 18 (3), 225–237.
- [92] McMahon, S.L., Koltzenburg, M., Tracey, I. and Turk, D.C. (2013). Peripheral Mechanisms of Cutaneous Nociception. Ringkamp, M., Raja, S. N., Campbell, J. N. and Meyer, R.A. (6 Ed), *Wall and Melzack's Textbook of Pain* (1-30). Philadelphia: ElsevierSaunders.
- [93] McMahon, S.L., Koltzenburg, M., Tracey, I. and Turk, D.C. (2013). Molecular Biology of Sensory Transduction. Gold, M.S. (6 Ed), *Wall and Melzack's Textbook of Pain* (31- 47). Philadelphia: ElsevierSaunders.
- [94] Cheng, Jen-Kun, and R.-R.J. (2008). Intracellular signaling in primary sensory neurons and persistent pain. *Neurochem. Res.*, 33 (10), 1970–1978.
- [95] Sukhomlinova, I. E., Tichonovskaya, M. A., Yeryomina, A. K., & Votava, W. E. (2015). Physiology of pain. Zaporozhye : ZSMU.
- [96] McMahon, S.L., Koltzenburg, M., Tracey, I. and Turk, D.C. (2013). Inflammatory Mediators and Modulators of Pain. Dawes, J. M., Andersson, D. A. (6 Ed), *Wall and Melzack's Textbook of Pain* (48-67). Philadelphia: ElsevierSaunders.
- [97] Isabella Gavazzi, Robin D.C. Kumar, S.B.M. and J.C. (1999). Growth responses of different subpopulations of adult sensory neurons to neurotrophic factors in vitro. *Eur. J. Neurosci.*, 11 (10), 3405–3414.
- [98] Barbacid, M. (1995). Neurotrophic factors and their receptors. *Curr. Opin. Cell Biol.*, 7 (2), 148–155.
- [99] Gascon, E., and Moqrich, A. (2010). Heterogeneity in primary nociceptive neurons: From molecules to pathology. *Arch. Pharm. Res.*, 33 (10), 1489–1507.
- [100] Bogen, O., Dreger, M., Gillen, C., Schröder, W., and Hucho, F. (2005). Identification of versican as an isolectin B4-binding glycoprotein from mammalian spinal cord tissue. *FEBS J.*, 272 (5), 1090–1102.
- [101] Fang, X., Djouhri, L., McMullan, S., Berry, C., Waxman, S.G., Okuse, K., and Lawson, S.N. (2006). Intense isolectin-B4 binding in rat dorsal root ganglion neurons distinguishes C-fiber nociceptors with broad action potentials and high Nav1.9 expression. *J. Neurosci.*, 26 (27), 7281–7292.
- [102] Belmonte, C., and Viana, F. (2008). Molecular and cellular limits to somatosensory specificity. *Mol. Pain*, 4 (1), 14.
- [103] Bishnoi, M., Bosgraaf, C.A., Abooj, M., Zhong, L., and Premkumar, L.S. (2011).

- Streptozotocin-Induced Early Thermal Hyperalgesia is independent of Glycemic State of Rats: Role of Transient Receptor Potential Vanilloid 1 (TRPV1) and Inflammatory mediators. *Mol. Pain*, 7 (1), 52.
- [104] Isensee, J., Diskar, M., Waldherr, S., Buschow, R., Hasenauer, J., Prinz, A., Allgöwer, F., Herberg, F.W., and Hucho, T. (2014). Pain modulators regulate the dynamics of PKA-RII phosphorylation in subgroups of sensory neurons. *J. Cell Sci.*, 127 (1), 216–229.
- [105] Ocaña, M., Cendán, C.M., Cobos, E.J., Entrena, J.M., and Baeyens, J.M. (2004). Potassium channels and pain: Present realities and future opportunities. *Eur. J. Pharmacol.*, 500 (1–3), 203–219.
- [106] Bae, J.Y., Kim, J.H., Cho, Y.S., Mah, W., and Bae, Y.C. (2015). Quantitative analysis of afferents expressing substance P, calcitonin gene-related peptide, isolectin B4, neurofilament 200, and Peripherin in the sensory root of the rat trigeminal ganglion. *J. Comp. Neurol.*, 523 (1), 126–138.
- [107] Andres, C., Meyer, S., Dina, O.A., Levine, J.D., and Hucho, T. (2010). Quantitative automated microscopy (QuAM) elucidates growth factor specific signalling in pain sensitization. *Mol. Pain*, 6 (1), 98.
- [108] Khasar, S.G., Lin, Y.H., Martin, A., Dadgar, J., McMahon, T., Wang, D., Hundle, B., Aley, K.O., Isenberg, W., McCarter, G., Green, P.G., Hodge, C.W., Levine, J.D., and Messing, R.O. (1999). A novel nociceptor signaling pathway revealed in protein kinase c ϵ mutant mice. *Neuron*, 24 (1), 253–260.
- [109] Lewin, G.R., Ritter, A.M., and Mendell, L.M. (1993). Nerve growth factor-induced hyperalgesia in the neonatal and adult rat. *J. Neurosci.*, 13 (5), 2136–2148.
- [110] Zochodne, D.W. (2015). Diabetes and the plasticity of sensory neurons. *Neurosci. Lett.*, 596, 60–65.
- [111] Russo, A.F. (2015). Calcitonin Gene-Related Peptide (CGRP): A New Target for Migraine. *Annu. Rev. Pharmacol. Toxicol.*, 55 (1), 533–552.
- [112] Gold, M.S., Levine, J.D., and Correa, A.M. (1998). Modulation of TTX-R I(Na) by PKC and PKA and their role in PGE2- induced sensitization of rat sensory neurons in vitro. *J. Neurosci.*, 18 (24), 10345–10355.
- [113] Bhave, G., Zhu, W., Wang, H., Brasier, D.J., Oxford, G.S., and Gereau IV, R.W. (2002). cAMP-dependent protein kinase regulates desensitization of the capsaicin

- receptor (VR1) by direct phosphorylation. *Neuron*, 35 (4), 721–731.
- [114] Sachs, D., Villarreal, C.F., Cunha, F.Q., Parada, C.A., and Ferreira, S.H. (2009). The role of PKA and PKC η pathways in prostaglandin E₂-mediated hypernociception. *Br. J. Pharmacol.*, 156 (5), 826–834.
- [115] taiwo, Y.O., and levine, J.D. (1991). Further confirmation of the role of adenylyl cyclase and of cAMP-dependent protein kinase in primary afferent hyperalgesia. *Neuroscience*, 44 (1), 131–135.
- [116] Aley, K.O., and Levine, J.D. (1999). Role of protein kinase A in the maintenance of inflammatory pain. *J. Neurosci.*, 19 (6), 2181–2186.
- [117] Aley, K.O., Martin, A., McMahon, T., Mok, J., Levine, J.D., and Messing, R.O. (2001). Nociceptor sensitization by extracellular signal-regulated kinases. *J. Neurosci.*, 21 (17), 6933–6939.
- [118] Ji, R. (2004). Peripheral and Central Mechanisms of Inflammatory Pain , with Emphasis on MAP Kinases. *Curr. Drug Targets-Inflammation Allergy*, 3 (3), 299–303.
- [119] Donnerer, J., and Liebmann, I. (2010). Dorsal root ganglion neurons respond with prolonged extracellular signal-regulated protein kinase phosphorylation following noxious heat and cold stimulation. *Neurosci. Lett.*, 472 (2), 109–113.
- [120] Galan, A., Cervero, F., and Laird, J.M.A. (2003). Extracellular signaling-regulated kinase-1 and -2 (ERK 1/2) mediate referred hyperalgesia in a murine model of visceral pain. *Mol. Brain Res.*, 116 (1–2), 126–134.
- [121] Lewin, G.R., Rueff, A., and Mendell, L.M. (1994). Peripheral and Central Mechanisms of NGF-induced Hyperalgesia. *Eur. J. Neurosci.*, 6 (12), 1903–1912.
- [122] Obata, K., and Noguchi, K. (2004). MAPK activation in nociceptive neurons and pain hypersensitivity. *Life Sci.*, 74 (21), 2643–2653.
- [123] Impey, S., Obrietan, K., and Storm, D.R. (1999). Making new connections: Role of ERK/MAP kinase signaling in neuronal plasticity. *Neuron*, 23 (1), 11–14.
- [124] Kiguchi, N., Maeda, T., Kobayashi, Y., Fukazawa, Y., and Kishioka, S. (2009). Activation of extracellular signal-regulated kinase in sciatic nerve contributes to neuropathic pain after partial sciatic nerve ligation in mice. *Anesth. Analg.*, 109 (4), 1305–1311.
- [125] Dai, Y., Iwata, K., Fukuoka, T., Kondo, E., Tokunaga, A., Yamanaka, H.,

- Tachibana, T., Liu, Y., and Noguchi, K. (2002). Phosphorylation of extracellular signal-regulated kinase in primary afferent neurons by noxious stimuli and its involvement in peripheral sensitization. *J. Neurosci.*, 22 (17), 7737–7745.
- [126] Edelmayer, R.M., Brederson, J.D., Jarvis, M.F., and Bitner, R.S. (2014). Biochemical and pharmacological assessment of MAP-kinase signaling along pain pathways in experimental rodent models: A potential tool for the discovery of novel antinociceptive therapeutics. *Biochem. Pharmacol.*, 87 (3), 390–398.
- [127] Ji, R.R., Gereau IV, R.W., Malcangio, M., and Strichartz, G.R. (2009). MAP kinase and pain. *Brain Res. Rev.*, 60 (1), 135–148.
- [128] (2016). Lodish, H., Berk, A., Zipursky, S.L., Matsudaira, P., Baltimore, D., and Darnell, J.(2016). Cells of the nervous system. (8th ed), *Molecular of the cell biology* (1026-1074). New York: W. H. Freeman and Company.
- [129] Yuan, J. (2013). Hereditary sensory and autonomic neuropathy type IID caused by an SCN9A mutation. *Neurology*, 80 (18), 1641–1650.
- [130] Leipold, E., Liebmann, L., Korenke, G.C., Heinrich, T., Gießelmann, S., Baets, J., Ebbinghaus, M., Goral, R.O., Stöddberg, T., Hennings, J.C., Bergmann, M., Altmüller, J., Thiele, H., Wetzel, A., Nürnberg, P., Timmerman, V., Jonghe, P. De, Blum, R., Schaible, H., Weis, J., Heinemann, S.H., Hübner, C.A., and Kurth, I. (2013). A de novo gain-of-function mutation in SCN11A causes loss of pain perception. *Nat. Genet.*, 45 (11), 1399–1404.
- [131] Hadley, J.K., Passmore, G.M., Tatulian, L., Al-Qatari, M., Ye, F., Wickenden, A.D., and Brown, D.A. (2003). Stoichiometry of expressed KCNQ2/KCNQ3 potassium channels and subunit composition of native ganglionic M channels deduced from block by tetraethylammonium. *J. Neurosci.*, 23 (12), 5012–5019.
- [132] Blackburn-Munro, G., and Jensen, B.S. (2003). The anticonvulsant retigabine attenuates nociceptive behaviours in rat models of persistent and neuropathic pain. *Eur. J. Pharmacol.*, 460 (2–3), 109–116.
- [133] von Hehn, C.A., Baron, R., and Woolf, C.J. (2012). Deconstructing the Neuropathic Pain Phenotype to Reveal Neural Mechanisms. *Neuron*, 73 (4), 638–652.
- [134] Marker, C.L., Stoffel, M., and Wickman, K. (2004). Spinal G-Protein-Gated K⁺ Channels Formed by GIRK1 and GIRK2 Subunits Modulate Thermal Nociception and Contribute to Morphine Analgesia. *J. Neurosci.*, 24 (11), 2806–

2812.

- [135] Barton, M.E., Eberle, E.L., and Shannon, H.E. (2005). The antihyperalgesic effects of the T-type calcium channel blockers ethosuximide, trimethadione, and mibefradil. *Eur. J. Pharmacol.*, 521 (1–3), 79–85.
- [136] Caterina, M.J., Schumacher, M.A., Tominaga, M., Rosen, T.A., Levine, J.D., and Julius, D. (1997). The capsaicin receptor : a heat-activated ion channel in the pain pathway. *Nature*, 389 (6653), 816–824.
- [137] Bautista, D.M., and Pellegrino, M. (2013). TRPA1 : A Gatekeeper for Inflammation. *Annu. Rev. Physiol.*, 75, 181–200.
- [138] Brône, B., Peeters, P.J., Marrannes, R., Mercken, M., Nuydens, R., Meert, T., and Gijssen, H.J.M. (2008). Tear gasses CN , CR , and CS are potent activators of the human TRPA1 receptor. *Toxicol. Appl. Pharmacol.*, 231 (2), 150–156.
- [139] Mcnamara, C.R., Mandel-brehm, J., Bautista, D.M., Siemens, J., Deranian, K.L., Zhao, M., Hayward, N.J., Chong, J.A., Julius, D., Moran, M.M., and Fanger, C.M. (2007). TRPA1 mediates formalin-induced pain. *Proc. Natl. Acad. Sci.*, 104 (33), 13525–13530.
- [140] Karashima, Y., Talavera, K., Everaerts, W., Janssens, A., Kwan, K.Y., and Vennekens, R. (2009). TRPA1 acts as a cold sensor in vitro and in vivo. *Proc. Natl. Acad. Sci.*, 106 (4), 1273–1278.
- [141] Kostyuk, P.G., Veselovsky, N.S., and Fedulova, S.A. (1981). Ionic currents in the somatic membrane of rat dorsal root ganglion neurons-II. Calcium currents. *Neuroscience*, 6 (12), 2431–2437.
- [142] Kostyuk, P.G., Veselovsky, N.S., and Tsyndrenko, A.Y. (1981). Ionic currents in the somatic membrane of rat dorsal root ganglion neurons. *Neuroscience*, 6 (12), 2423–2430.
- [143] Liu, P.W., Blair, N.T., and Bean, B.P. (2017). Action potential broadening in capsaicin-sensitive DRG neurons from frequency-dependent reduction of Kv3 current. *J. Neurosci.*, 37 (40), 9705–9714.
- [144] Bertil, H. (2001). *Ionic channels of excitable membranes*.(3rd ed). Sunderland, Massachusetts: Sinauer Associates, Inc.
- [145] Hyun, S.W., Kim, B.R., Hyun, S.A., and Seo, J.W. (2017). The assessment of electrophysiological activity in human-induced pluripotent stem cell-derived cardiomyocytes exposed to dimethyl sulfoxide and ethanol by manual patch

- clamp and multi-electrode array system. *J. Pharmacol. Toxicol. Methods*, 87, 93–98.
- [146] Hodgkin, Alan L., and A.F.H. (1952). A quantitative description of membrane current and its application to conduction and excitation in nerve. *J. Physiol.*, 117 (4), 500–544.
- [147] Hamill, O.P., Marty, A., Neher, E., Sakmann, B., and Sigworth, F.J. (1981). Improved patch-clamp techniques for high-resolution current recording from cells and cell-free membrane patches. *Pflügers Arch. Eur. J. Physiol.*, 391 (2), 85–100.
- [148] Duque, A.P.D.N., Pinto, N.D.C.C., Mendes, R.D.F., Da Silva, J.M., Aragão, D.M.D.O., Castañon, M.C.M.N., and Scio, E. (2016). In vivo wound healing activity of gels containing *Cecropia pachystachya* leaves. *J. Pharm. Pharmacol.*, 68 (1), 128–138.
- [149] Heinrich, T., Hübner, C., and Kurth, I. (2016). Isolation and Primary Cell Culture of Mouse Dorsal Root Ganglion Neurons. *Bio-Protocol*, 6 (7), 1–8.
- [150] De Luca, A.C., Faroni, A., and Reid, A.J. (2015). Dorsal root ganglia neurons and differentiated adipose-derived stem cells: An in vitro co-culture model to study peripheral nerve regeneration. *J. Vis. Exp.*, 96 (96), 1–9.
- [151] Cummins, T.R., Rush, A.M., Estacion, M., Dib-Hajj, S.D., and Waxman, S.G. (2009). Voltage-clamp and current-clamp recordings from mammalian DRG neurons. *Nat. Protoc.*, 4 (8), 1103–1112.
- [152] Shi, Y., Liang, X., Zhang, H., Wu, Q., Qu, L., and Sun, Q. (2013). Quercetin protects rat dorsal root ganglion neurons against high glucose-induced injury in vitro through Nrf-2 / HO-1 activation and NF- κ B inhibition. *Nat. Publ. Gr.*, 34 (9), 1140–1148.
- [153] Großkreutz, J., Quasthoff, S., Kühn, M., and Grafe, P. (1996). calcium potentials and tetrodotoxin-resistant sodium potentials in unmyelinated C fibres of biopsied human sural nerve. *Neurosci. Lett.*, 208 (1), 49–52.
- [154] Passmore, G.M., Selyanko, A.A., Mistry, M., Al-Qatari, M., Marsh, S.J., Matthews, E.A., Dickenson, A.H., Brown, T.A., Burbidge, S.A., Main, M., and Brown, D.A. (2003). KCNQ/M currents in sensory neurons: Significance for pain therapy. *J. Neurosci.*, 23 (18), 7227–7236.
- [155] Kajander, K.C., and Bennett, G.J. (1992). Onset of a painful peripheral

neuropathy in rat: A partial and differential deafferentation and spontaneous discharge in A β and A δ primary afferent neurons. *J. Neurophysiol.*, 68 (3), 734–744.